

COMPARING
PLANE REGULAR SHAPE THEORY
WITH
CURRENT SCIENTIFIC THEORIES

A FURTHER TREATISE ON A THEORY OF SHAPE

WHO KNEW WHAT & WHEN?
HOW DID THEY KNOW?

A CONTRIBUTION TOWARDS THE THEORY OF EVERYTHING

PART OF AN INTRO TO SUPERSYMMETRY?

By

John Marcus Crombie

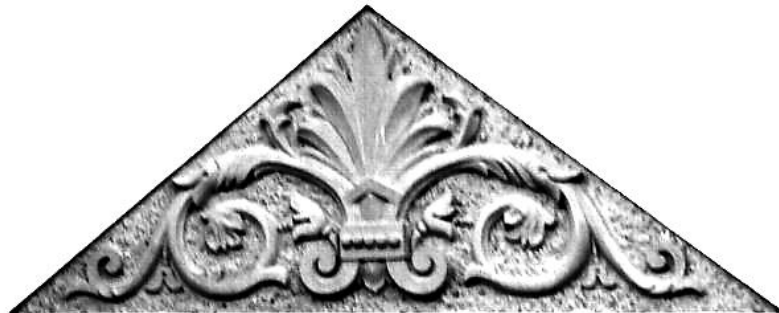

By:

JOHN M. CROMBIE
47 Sizer Street, Everton Park,
Brisbane Q. 4053

Ph. Mob. 0412 176 627
Email: johnmcrombie51@gmail.com

© 2026 *JOHN MARCUS CROMBIE*. All rights reserved. Except for the quotation of short passages for the purposes of criticism and review, no part of this publication may be reproduced, stored in a retrieval system, or transmitted in any form or by any means, electronic, mechanical, photocopying, recording, or otherwise, without the prior written permission of the Author or the publisher.

I claim the contents of this book as my own intellectual property except where I have quoted from the works of others.

This book is proudly published and produced in Australia.

PRINTED BY:

Minuteman Press Sunshine Coast
Address: 2a22 Premier Circuit,
Warana QLD 4575
Phone: (07) 5493 9637

Metafile:

Concepts: Antedeluvian; **Audible Frequencies**; Biological Cell Analysis; Big Bang; Black Holes; Catalysts; Chaos Theory; Circumscribing and Inscribing Circles; Concentric Circles; Conceptuality; **Cymatics**; Dark Matter; 'Dolphin Speak'; Diatoms; "Elegant Ratios"; **Enmeduranki**; **Eratosthanes**; **Euclid**; FFT **Fourier** Fast Transforms; Frequency; General Theory of Relativity and Quantum Mechanics; **Genome of Shape**; **Glaucon**; Golden Mean; Golden Mean Equation; **Harmonics**; Incommensurables; Infinity; **Dr. Hans Jenny**; **Kepler**; Kibdu Secrets; **Alexander Lauterwasser**; Matrix; Marad; **Meno**; Obelisks; Photo Voltaic Cells; **Plato**; Polygons or Polygrams; Pre-Euclidean Ratio Theory; Primary Ratios; **Ptolemy**; a general theory of Proportion; Quadrature; Quantum Theory; Ratios; Ratio-System; Reciprocals; **Republic**; Seven Concentric Circles; Sessile Drops; Sexagesimals; Shape Ratio Theorems; the Singularity; Stonehenge; **Timeaus**; **Theaetetus**; Two-dimensional Plane Regular Shape; Units of Measurement; Versailles Palace; Visual Mathematics; '360 Degrees';

10 9 8 7 6 5 4 3 2 1

He too knew the square root of two.

and

He knew the square root of two too.

AN INTRODUCTION TO PLANE REGULAR SHAPE

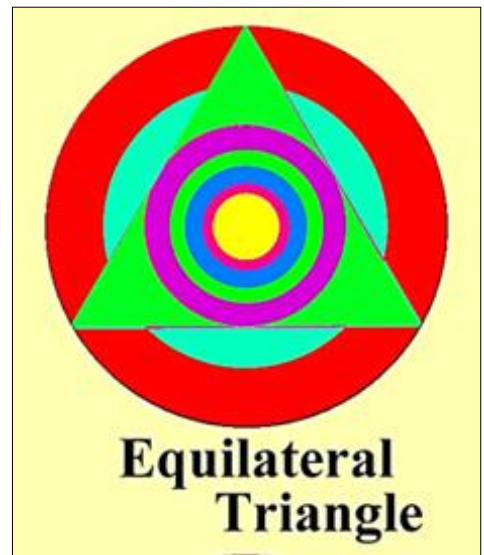
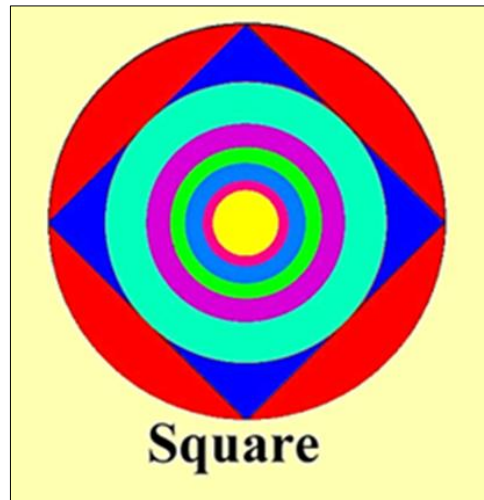
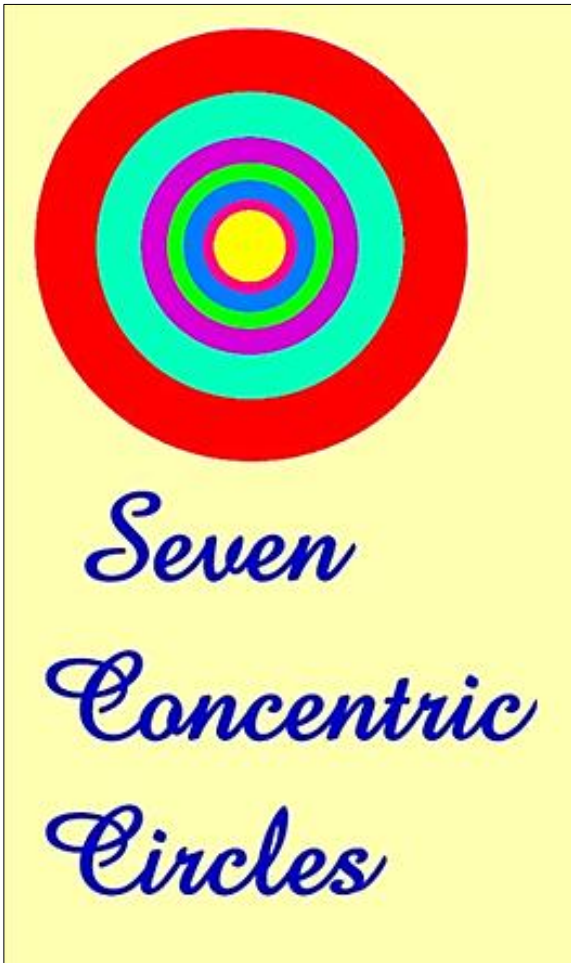

ALL
WITH SAME CIRCUMSCRIBING CIRCLE:
BUT DIFFERENT INSCRIBING CIRCLES

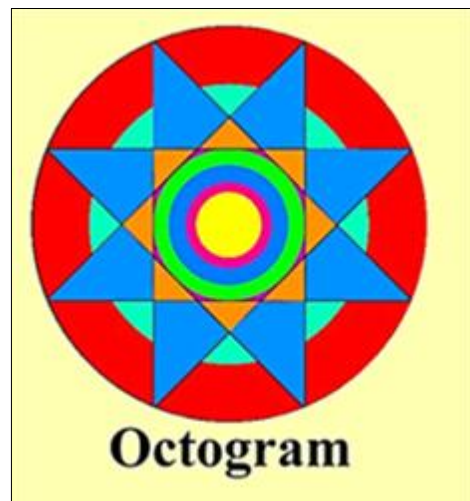
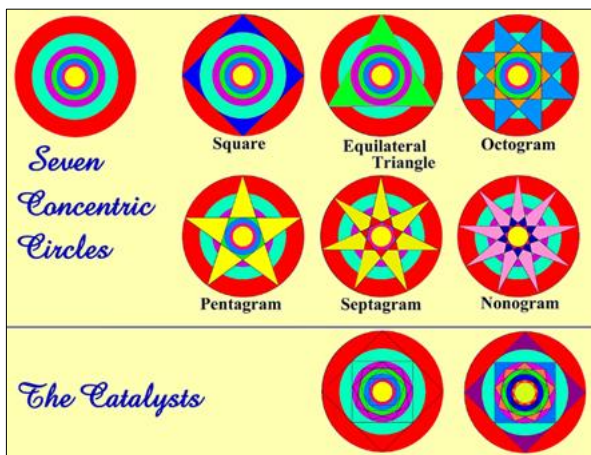

Catalysts

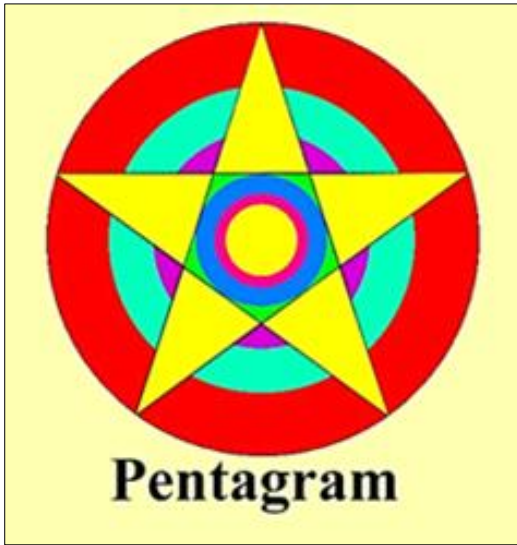

Pentagram

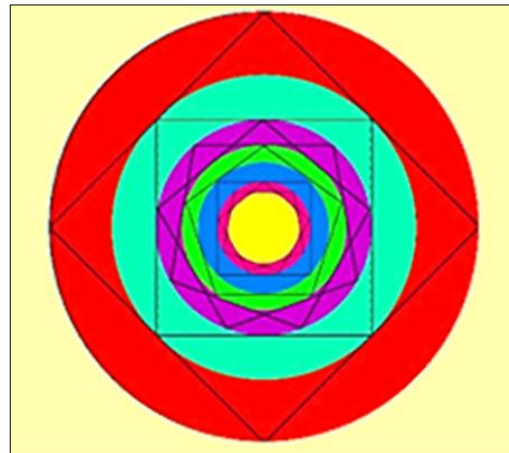

THE SHAPES BETWEEN THESE SAME CIRCLES

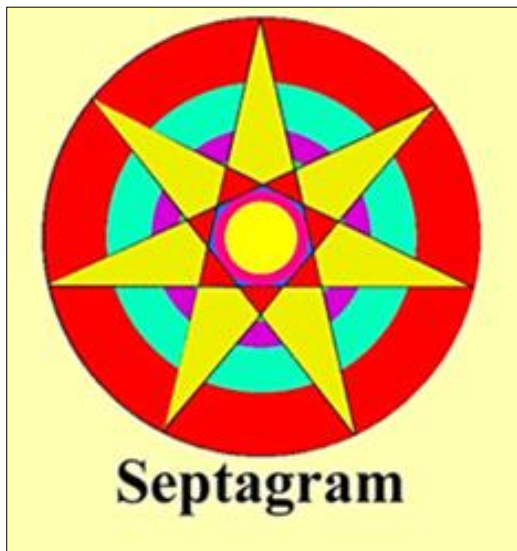

Septagram

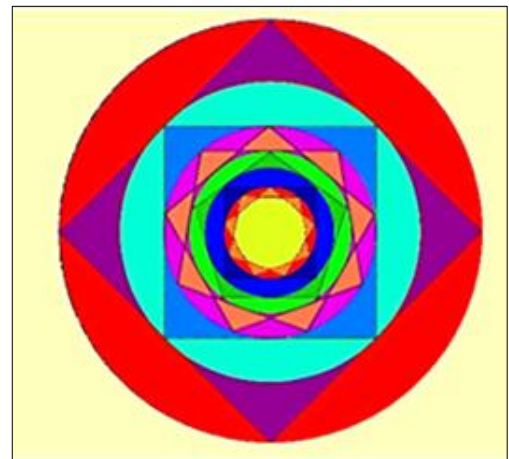

When **three or more** Plane Regular Shapes and their Circles are *Nested* then because **Shape x Shape = Shape** the ratio of **any pair** of these circles will produce a Plane Regular Shape.

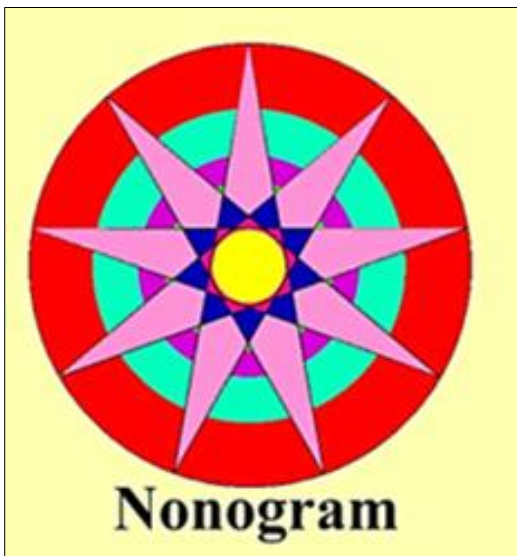

Nonogram

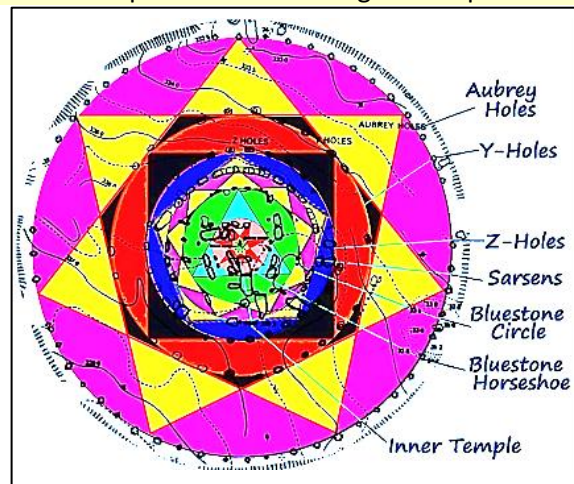

AND SO IT IS AT STONEHENGE.

MY THEORY
OF
PLANE REGULAR SHAPE

A PRECIS

Shape x Shape = Shape.

Graphically & Mathematically

Plane Regular Shape:-

- is Equilinear and Equiangular.
- Has a Circumscribing Circle **and** an Inscribing Circle.
- And each shape's pair of these circles is in **a ratio that is unique** to that shape.
- The concept that is 'area' does not arise in the analysis and measurement of Plane Regular Shape and thus we are dealing with 'circles' without the need for π .
- Physical Size is irrelevant to the analysis of Plane Regular Shapes. A shape the size of a thimble or a Diatom has the same Ratio as the same shape the size of the Universe (or of Saturn or Jupiter.).

MATHEMATICALLY,

- When one shape's ratio is **multiplied** by another shape's ratio the resulting number is the ratio for a third shape.
Thus,
$$\text{Shape} \times \text{Shape} = \text{Shape}.$$
- When one shape's ratio is **divided** by another shape's ratio the resulting number is the ratio for a third shape.
$$\text{Shape} / \text{Shape} = \text{Shape}.$$
- When one shape's ratio is **halved or doubled** it is divided or multiplied by 2 and 2 is the ratio for a shape, (the Equilateral Triangle), so once again
$$\text{Shape} \times \text{Shape} = \text{Shape}.$$
- When one shape's ratio is **squared** the resulting number is the ratio for another shape. Squaring a shape is, after all, multiplying a shape by a shape.
$$\text{Shape} \times \text{Shape} = \text{Shape}.$$

CURRENT SCIENCE

"Plane Regular Shape:-
is Equilinear and Equiangular."

Regular Shapes

All regular 2d shapes, or regular polygons, have special properties listed below.

Regular Shapes Properties

- All regular polygons have all their sides equal in length.
- All regular polygons have all their angles equal.
- All regular polygons have the same number of lines of symmetry as their sides.

The formulae for the interior angles of a polygon are as follows:

Total of interior angles = 180 x (number of sides - 2)

Angle = total of interior angles / number of sides

Prof. Brian Cox

at page 41 of "Forces of Nature" book

"This isn't intended to be a complete course on particle physics much as I'd like to deliver that; rather, it is a chapter about **shapes and patterns in Nature** and what they reveal about the way in which the Universe works."

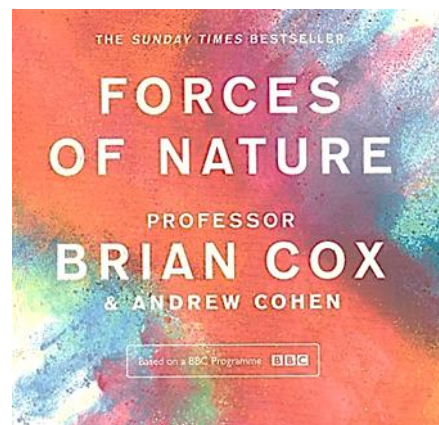

Symmetry

MY THEORY

PLANE REGULAR SHAPES can interact with each other:

GRAPHICALLY

Via their Images:

- As a Single Shape
- As a 'Construction' Shape
- As a 'Mathematical' Shape
- As a 'Shape in Phase'.

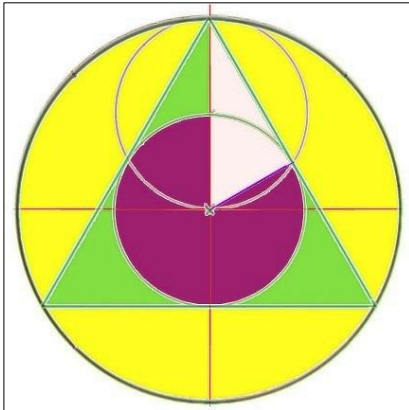

OR

MATHEMATICALLY

Via their Ratios

- As a Single Shape
- As a 'Construction' Shape
- As a 'Mathematical' Shape
- As a 'Shape in Phase'.

AND

PLANE REGULAR SHAPES can interact with each other and with other entities:

- As Single Shapes;
- As 'Construction' Shapes;
- As 'Mathematical' Shapes;
- As 'Shapes in Phase';
- As Primary Shapes;
- As Intermediate Shapes;
- As Prime Shapes;
- As Prime Shapes in Phase;

Some other applicable entities that resonate with the Ratios of Plane Regular Shape:

- Sound Frequencies and Music.
- Square Roots.
- Centric Diatoms.

CURRENT SCIENCE

CYMATICS or MODAL PHENOMENA

ME

Knowledge or potential knowledge of this candidate for the title of 'science' has been around for 500 years and there have been several notables who have noticed its presence in the world around us. The graphical results of cymatics experiments have long produced 'pleasant' results for those who dared to experiment but nothing of any substance was added to the knowledge base in the area of Maths/Physics. What has been missing for these 500 years and possibly since time began, was a workable theory of Plane Regular Shape. All Cymatic results to date have been solely measured against the Music Scale and its relevance is slowly being established. It is generally accepted that the pleasant results obtained are generally of a regular geometric nature. But, this has been a one-sided view of the phenomena. Without a theory of shape that is relevant to the Cymatic results all hard work done to date has been in vain.

Brian Greene

STRING THEORY

- ❖ Branes
- ❖ Multiverses
- ❖ "Limited Individual Infinities"

MY THEORY

GRAPHICAL MATHEMATICS FOR THE BEGINNER

GRAPHICALLY AND MATHEMATICALLY PORTRAYING
THE SHAPE THEOREM

THE SHAPE THEOREM:

"A SHAPE RATIO MULTIPLIED or DIVIDED BY ANOTHER
SHAPE RATIO
PRODUCES THE RATIO FOR A THIRD SHAPE."

This theorem is the basis for the existence of the
Harmonics of Plane Regular Shape.

This theorem is the basis for the applicability of
The Matrix in deriving shape ratios.

If a unique mathematical value can be found for
EACH Plane Regular Shape

&

If this theorem can be applied universally to ALL
Plane Regular Shapes

&

If we can accept that the results of all Cymatics
experiments (*shapes produced by vibration using
Circular containers*) are in fact Plane Regular
Shapes

Then, WE WILL HAVE A SYSTEM OF MATHEMATICS
THAT WILL ACCOUNT FOR THE RESULTS OF ALL
CYMATICS EXPERIMENTS.

&

POSSIBLY RESULTS OF SOME OTHER EXPERIMENTS
THAT USE FREQUENCIES TO EXCITE LIQUIDS.

SQUARE X SQUARE X SQUARE (Graphically)

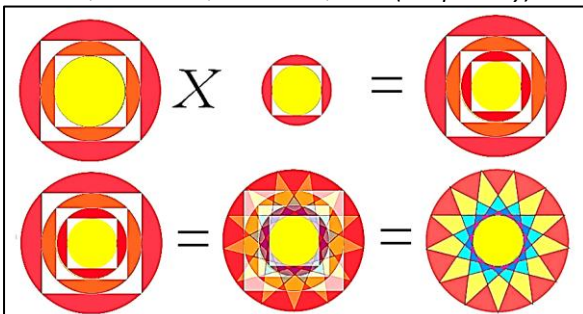

$$\sqrt{2} \times \sqrt{2} \times \sqrt{2} = 2.828427125 \text{ (13 point Polygram)}$$

$$1.414213562 \times 1.414213562 \times 1.414213562$$

$$= 2.828427125 \text{ (Mathematically)}$$

$$\text{Square} \times \text{Square} \times \text{Square} = \text{a 13 point Polygram (ratio } 2\sqrt{2} = 2.828427125)$$

CURRENT SCIENCE

Kepler

"Almost a whole summer was wasted on this ordeal. Eventually by a certain mere accident I chanced to come closer to the actual state of affairs."

"I thought it was by divine intervention that I gained fortuitously what I was never able to obtain by any amount of toil; and I believed that all the more because I had always prayed to God that if Copernicus had told the truth things should proceed in this way."

[Kepler goes on to describe his idea of **inscribing and circumscribing circles** about a set of regular polygons thus generating a series of **nesting circles** whose sizes are constrained by the numbers of sides of each polygon. He abandons this when he realizes there is **no natural limit on the number of possible polygons** while there is a limit to the number of planets observed.]

Hans Jenny, p273 (8):

JENNY: "If two frequencies are made to impinge on one and the same liquid system, a figure appears which is the resultant of these actions. Each frequency produces a definite figure of its own. The resultant is a "third" figure (Figs. 156 – 164)."

My Theory:

What Jenny is stating here is my Shape Theorem: -
Shape Ratio x Shape Ratio = A Third Shape Ratio.
(He doesn't actually know or use the ratios.)

It is this feature of the Shape Ratios that give them their Harmonic flavour.

From this Theorem I proceeded to what I called my **Stonehenge Theorem** because it is the place I first found these phenomena:

"In any set of 3 or more Concentric Circles where each adjacent pair of circles produces a shape then any pair of circles in this set, adjacent or otherwise, will produce a shape."

Dr. Hans Jenny has seen what I call 'Graphical Mathematics' at work.

MY THEORY

PLANE REGULAR SHAPES can interact with each other:

➤ *As 'Mathematical' Shapes*

e.g.

| |
|--------------------------|
| 10 degrees |
| 36 points |
| Ratio 16.00000000 |

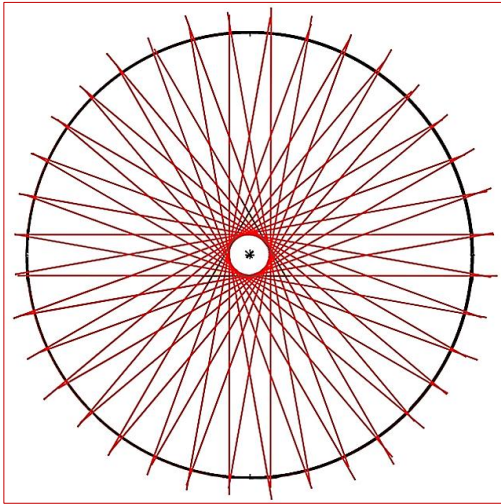

Whilst '**Construction**' lines form the obvious shapes in this example, the points where they intersect produce 'Escher' like circular effects. These 'Escher' circles are actually the **hidden** Circumscribing and Inscribing Circles for the hidden unseen 'Mathematical' Shapes contained within the outlined 'Construction' shapes.

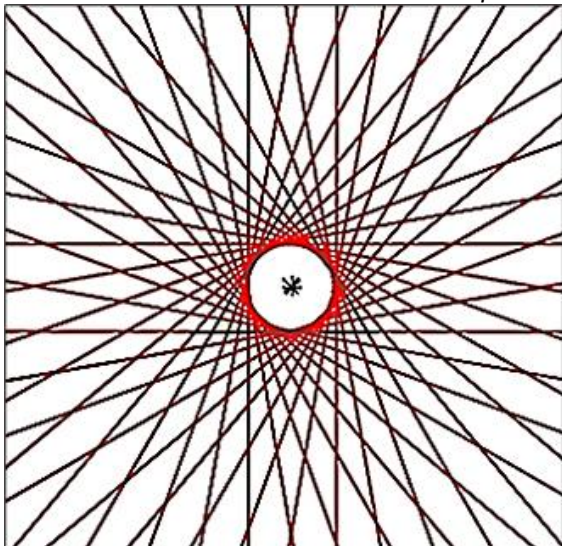

The product of the multiplication of the ratios for **all** these 'Mathematical' Shapes will produce the *Mathematical (and Graphical) ratio* for the overall shape, because:

Shape x Shape = Shape

CURRENT SCIENCE

RAMANUJAN

?

CONTINUED FRACTIONS

MAURITS CORNELIS ESCHER

MY THEORY

BASE SHAPE – 34 PT POLYGRAM (or 2x17 in phase)

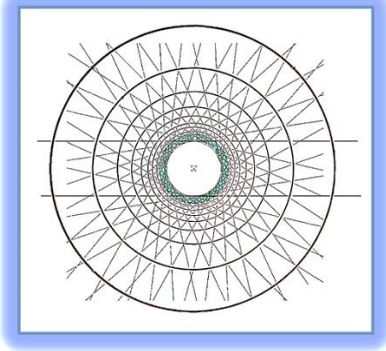

?

INTERNAL MATHEMATICAL SHAPES

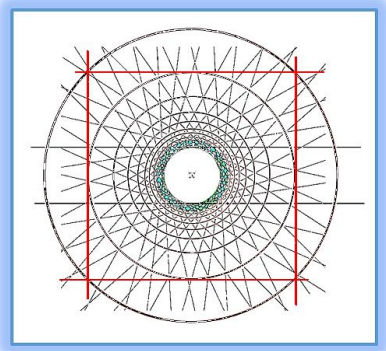

SQUARE – Ratio 1.414213562

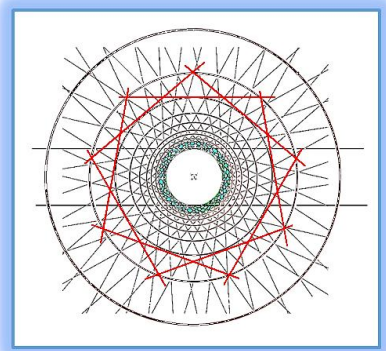

INNER NONOGRAM – Ratio 1.309016995

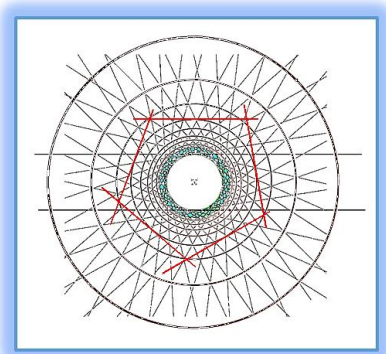

PENTAGON – Ratio 1.236067978

CURRENT SCIENCE

MY THEORY

CURRENT SCIENCE

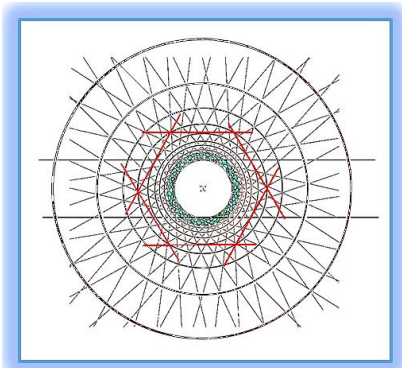

HEXAGON– Ratio 1.154700538379250

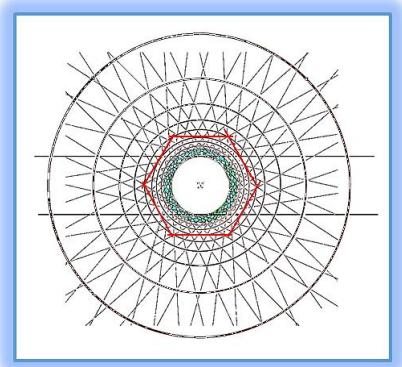

HEXAGON – Ratio 1.154700538379250

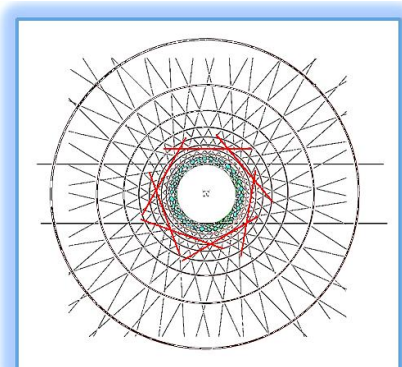

SEPTAGON – Ratio 1.104854344
7pts 128.5714 septagon, 1.104854344

Shape x Shape = Shape

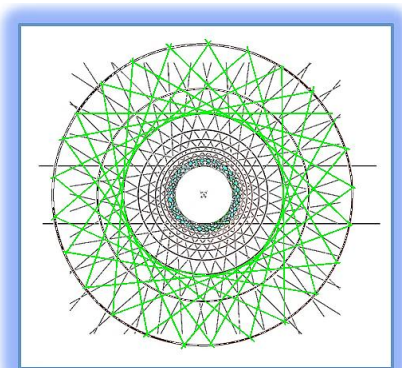

?

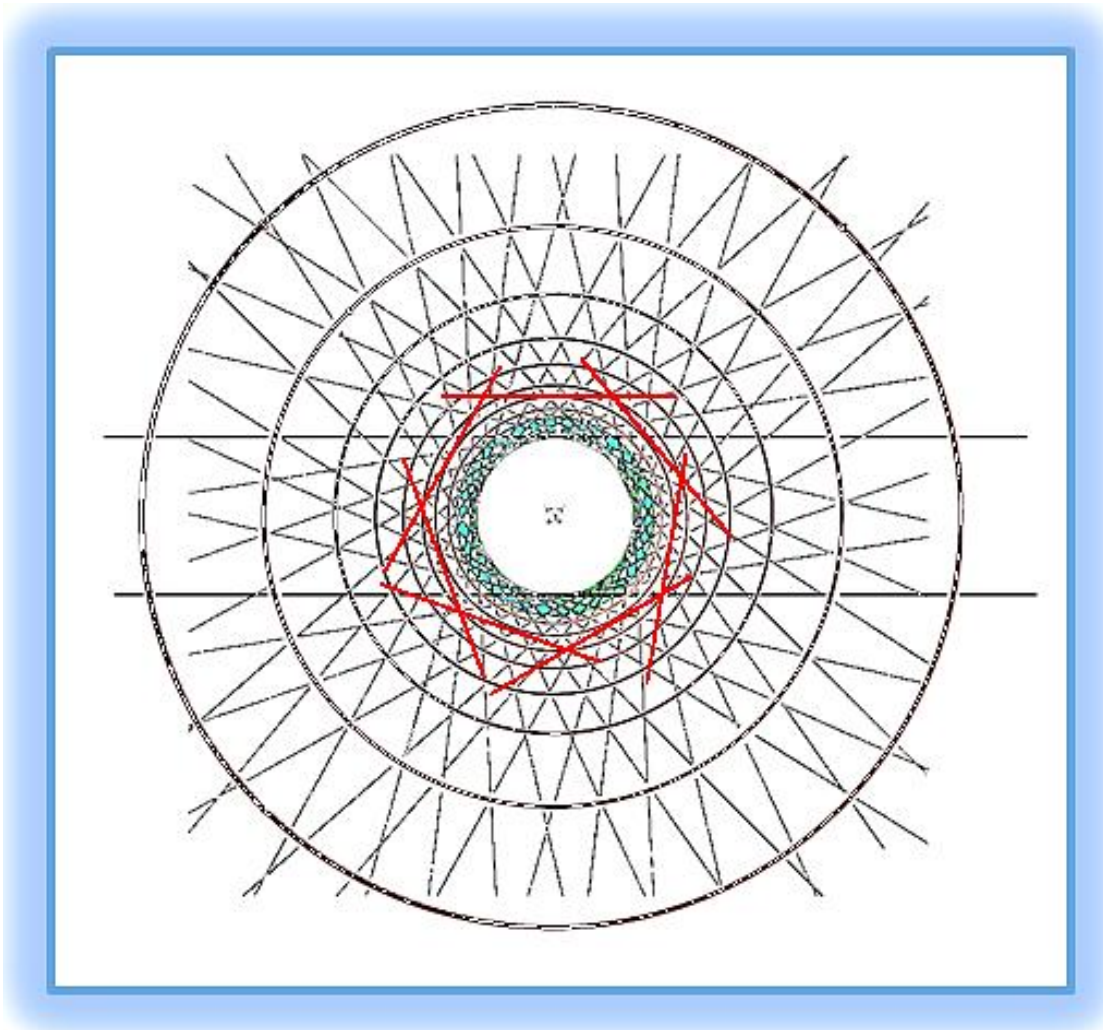

SEPTAGON – Ratio

7pts 128.5714 degrees Septagon, Ratio 1.104854344000000

0.5 - 1 - 0.5 - 2 ----- THE RECIPROCAL TO CODE 2 - 1 - 2 - 0.5

| Prime Multiplier | Points | Degrees | Points x Degrees | (Points x Degrees) / 360 |
|------------------|--------|--------------------|------------------|--------------------------|
| x7 | 7 | 25.714285714285700 | 180 | 0.5 |

| | | | |
|----|----------------------------|-------------------|-------------------|
| 77 | 7pts ϕ 77.14285714deg | 1.618033989000000 | 1.618033988749890 |
|----|----------------------------|-------------------|-------------------|

| | | |
|-----|------------------------|-------------------|
| 128 | 7pts 128.5714 septagon | 1.104854344000000 |
|-----|------------------------|-------------------|

MY THEORY

CURRENT SCIENCE

DEALING WITH MATHEMATICAL SHAPES:

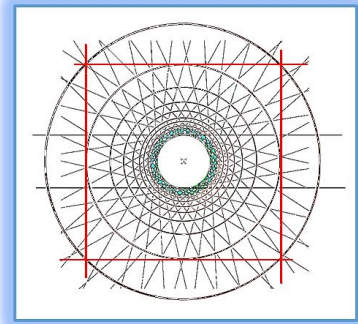

SQUARE – Ratio 1.414213562
MULTIPLIED BY

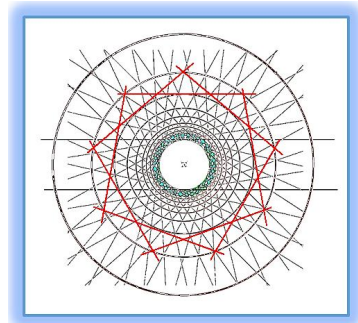

INNER NONOGRAM – Ratio 1.309016995
EQUALS

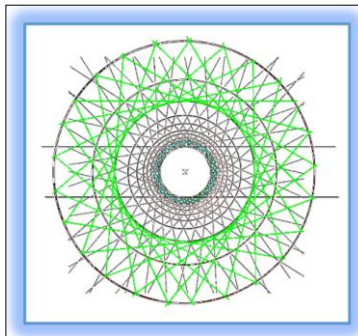

WHATEVER IT IS:
Ratio 1.414213562 X Ratio 1.309016995
Equals Ratio 1.851229586821910
WHICH RESULTS IN:
66 DEGREES 60 POINTS

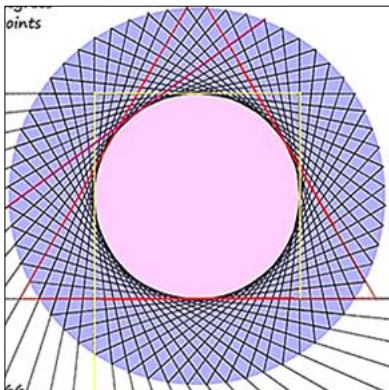

?

*Shape x Shape = Shape
Ratio x Ratio = Ratio*

Inner Nonogram 1.309016994374940
X
Square 1.414213562
= 1.851229586821910

= 60pts 66deg

MY THEORY

Shape x Shape = Shape
Graphically & Mathematically.

**EQUILATERAL TRIANGLE X INNER SEPTAGRAM
 = PENTAGRAM**

GRAPHICALLY:

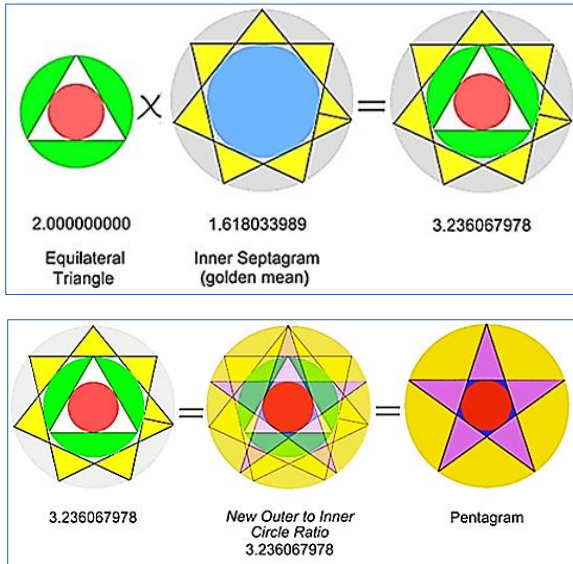

MORE GRAPHICAL PORTRAYALS: -
 Octagram / Square = 72 Point Polygram
(Shared Outer Circles)

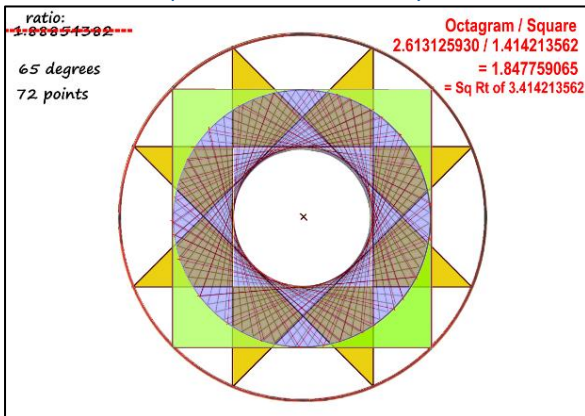

(New Shape formed between Inner Circles)

MATHEMATICAL PORTRAYAL: -
 Octagram / Square = 72 Point Polygram
 $2.613125930 / 1.414213562 = 1.847759065$

NOTE: $1.847759065 = \sqrt{3.414213562}$
 $= \sqrt{(2 + 1.414213562)}$
 $= \sqrt{(2 + \sqrt{2})}$

$= \sqrt{(\text{Equilateral Triangle} + \text{a Square})}$
(But ratios are multiplied and not added.)

But $2 \times 2 = 4 \dots$ And $2 + 2 = 4$

This is a 'Ramanujan' type of Continuous fraction.

CURRENT SCIENCE

Ptolemy's Chords

This is one of my portrayals of the science developed from that outlined by Claudius Ptolemy c.150ad.

20 POINT POLYGON TO 20 POINT POLYGRAM

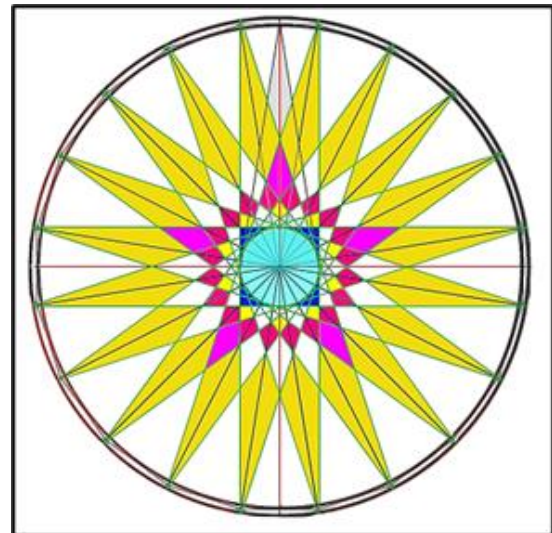

The Harmonics

Includes A Pentagram in phase with itself 4 times.
An Ancient example of "Entanglement"?
*This Pentagram is a **Construction Shape** as it is formed by the construction lines of the outer primary shape.*

PTOLEMY'S STEPS

- TAKE A CIRCLE
- SELECT A CHORD
- ISOLATE THE CHORD TRIANGLE
- INVERT THE CHORD TRIANGLE
- LOCATE ITS BASE ALONG THE DIAMETER

MY ADAPTION OF PTOLEMY'S STEPS

- USE THE LENGTH OF THE BASE AS THE DIAMETER OF AN INSCRIBING CIRCLE
- FORM A SHAPE USING THIS 'NEW' SET OF CIRCUMSCRIBING AND INSCRIBING CIRCLES.
- A SHAPE WILL BE FORMED USING THE NEW INSCRIBING CIRCLE WITH EITHER THE ORIGINAL CIRCUMSCRIBING CIRCLE OR THE INNER CIRCLE OF THE POLYGON (as a new Circumscribing Circle).

Because of the Shape Theorem any pair of these circles will now produce a Plane Regular Shape.

Shape x Shape = Shape

MY THEORY

CURRENT SCIENCE

MY MATHS:

1445/750
 ratio
 1.926610162
 40 points
 63 degrees
 degrees contained $40 \times 63 = 2520$
 multiples of 360..... $7 \times 360 = 2520$

?

RESULTING CONSTRUCTION SHAPES:

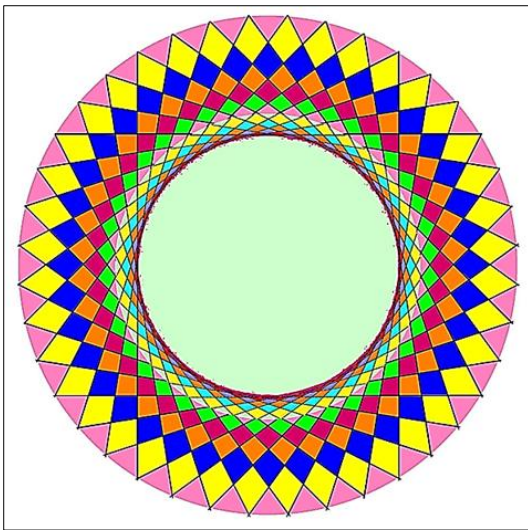

CONSTRUCTION SHAPES EXTENDED

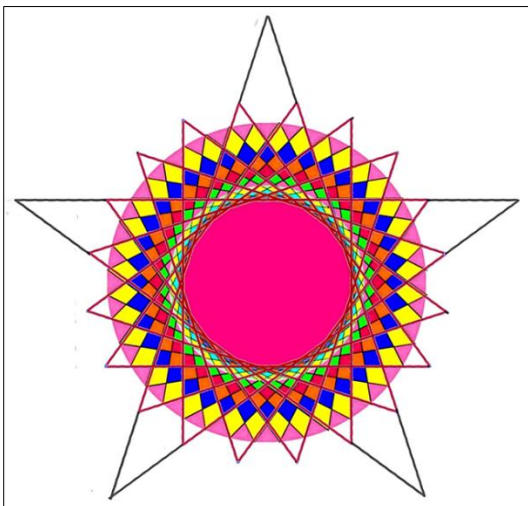

ENTANGLEMENT

A PENTAGRAM IN PHASE WITH ITSELF, 4 TIMES

Only one phase of the shape is shown. The construction lines for the other three have not yet been drawn.

The Construction lines that have apexes just inside those for the Pentagrams form a 40 Point Polygram. (actually 2 x 20 points in phase) I have only indicated 1x20 point polygram.

MY THEORY
SHAPES IN PHASE &
PHYSICAL EXAMPLES OF ENTANGLEMENT?
Phase ANALYSIS of a DIATOM:

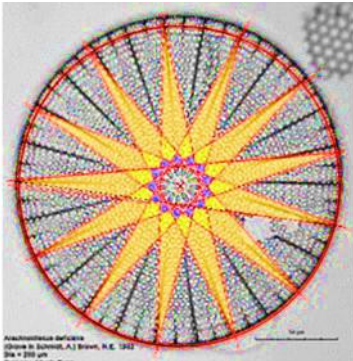

1 x 13-point polygram

Note the Relevant Inner & Outer Circles that exist in the Diatom's frustule ornamentation.

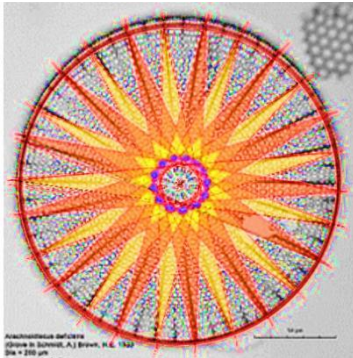

2 x 13-point polygrams in phase
 Between the Same Inner & Outer Circles

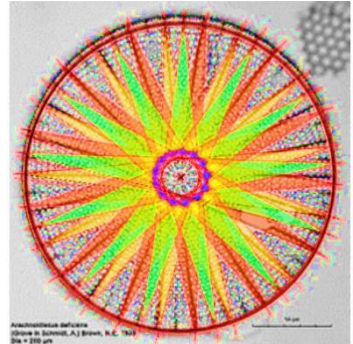

3 x 13-point polygrams in phase
 Between the Same Inner & Outer Circles

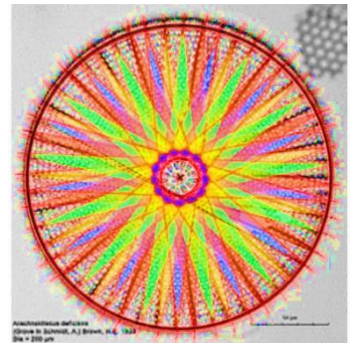

4 x 13-point polygrams in phase
 Between the Same Inner & Outer Circles

CURRENT NUCLEAR SCIENCE
PARTICLE ENTANGLEMENT

"**Albert Einstein** and **Niels Bohr** engaged in a long-running collegial dispute over **the interpretation of quantum mechanics**, now known as the Bohr–Einstein debates. During these debates, Einstein introduced a thought experiment involving a box that emits a photon." He noted that:

"The experimenter's choice of which measurement to make on the box would change what can be predicted about the photon, even when the photon is very far away."

"This argument, which Einstein had formulated by 1931, was an early recognition of what would later be called **entanglement**.^[20] That same year, Hermann Weyl observed in his textbook on group theory and quantum mechanics that "**quantum systems composed of multiple interacting parts exhibit a kind of Gestalt, in which the whole is greater than the sum of its parts**".^{[21][22]} In 1932, Erwin Schrödinger derived the defining equations of quantum entanglement but left them unpublished."^[23]

"In 1935, Grete Hermann studied the mathematics of an electron interacting with a photon and noted the phenomenon that would later be called **entanglement**."^[24]

"Later that same year, Einstein, Boris Podolsky and Nathan Rosen published a paper on what is now known as the Einstein–Podolsky–Rosen (EPR) paradox, a thought experiment that attempted to show that "the quantum-mechanical description of physical reality given by wave functions is not complete".^[2]

"Their thought experiment considered two systems that interact and then separate, and they argued that, afterward: "

'quantum mechanics could not describe the two systems individually.'

ME

Even given the nature & wide application of my equation, Shape x Shape = Shape
 my **Plane Regular Shape Theory**, by itself, **cannot describe or explain the existence of "Shapes in Phase" between the same circles bearing the same ratio as if it was a single shape.**

But can the Diatom that produced it explain it?

SHAPES IN PHASE

DIATOMS

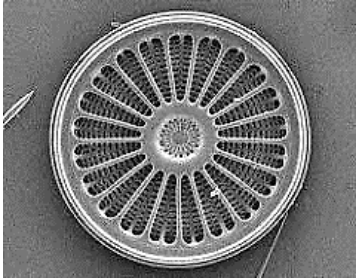

21 / 42 points

Or 3 x 14 points – or 3 x 7 points in Phase

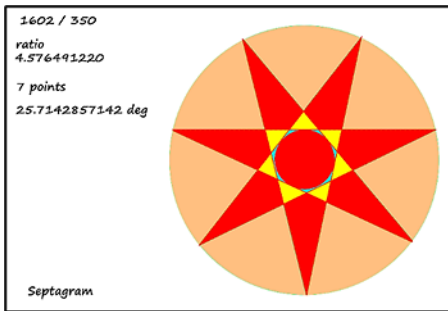

ENTANGLEMENT

3 x 7 point septagrams in phase

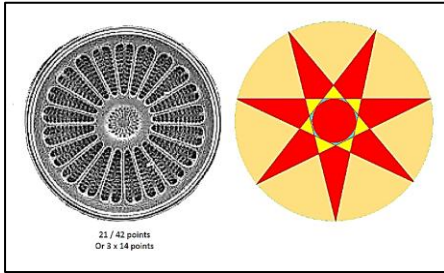

Showing the possibility of 3 x 7 points

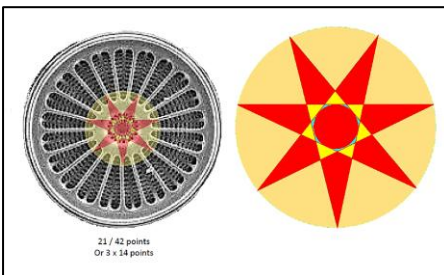
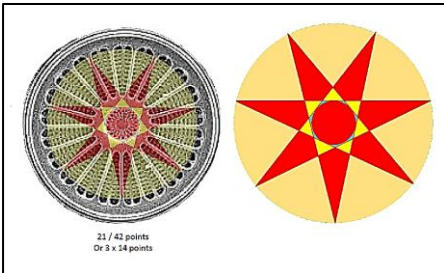

ENTANGLEMENT

MY THEORY

Is it possible that some Plane Regular Shape Ratios can actually produce Shapes-in-Phase?

If so, can they produce or are they already producing "Entanglement"?

Or is this impossible?

ONE OF MY CYMATICS EXPERIMENTS:



Septagram at 146.6 Hz (D₂)

Not Entangled.

Red Petals are the Outer Septagram.

White Petals are the Inner Septagram.

(Whilst attempting to align Music Frequencies with Shape Ratios).

(Whilst in the course of correlating Music with Shape).

MY THEORY

MY PARADOX

The **Mathematics** of Plane Regular Shape does not delineate, identify or describe **Shapes in Phase** as separate items sharing the same pair of Circles but . . . the **Graphics** of Plane Regular Shape does.

Each Plane Regular Shape has its own identifying *Shape Ratio* but several **Shapes in Phase** with each other must share the same Ratio and its pair of circles.

Each separate depiction of a Shape in a "**Shapes in Phase**" Set is formed separately by the same set of circles and bears the same Ratio conjointly with others in the set.

**PHYSICAL EXAMPLES OF ENTANGLEMENT
IN PLANE REGULAR SHAPE**

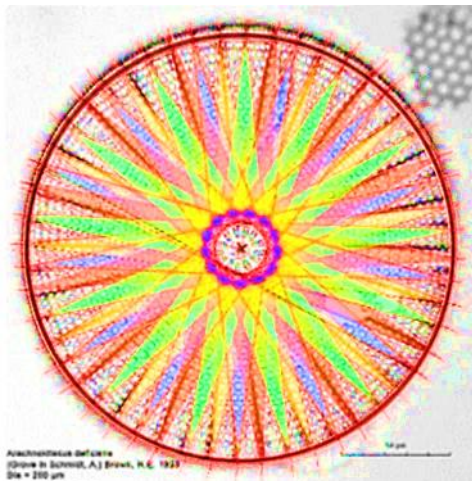

MY "Circle of Harmony" THEORY

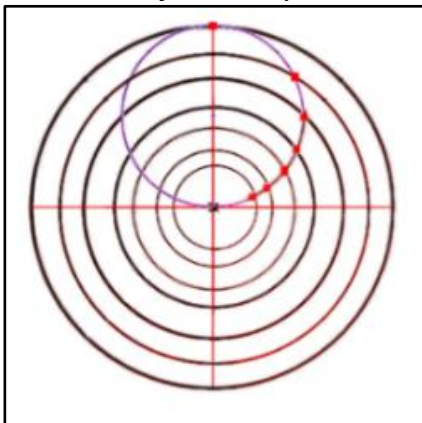

A STATIC IMAGE of Dynamic Events.

CURRENT NUCLEAR SCIENCE

THEIR PARADOX

"Many aspects of **quantum mechanics** yield unexpected results, defying expectations and deemed counterintuitive.^[3] "

"These aspects can seem paradoxical as they map behaviours quite differently from those seen at larger scales. In the words of quantum physicist Richard Feynman, "

Quantum mechanics deals with "Nature as she is—absurd".^[4]

I wonder if Cymatics research done by LINDON GLEDHILL using a 5000 frames per second camera may just give us some small visible insight into 'Entanglement' of Plane Regular Shapes-in-phase.

What is the **paradox of quantum theory**?

"The "*paradox*" here is that we can measure things remotely in ways that, while limited, defy our sense of time and space."

ATLAS EXPERIMENTS AT CERN

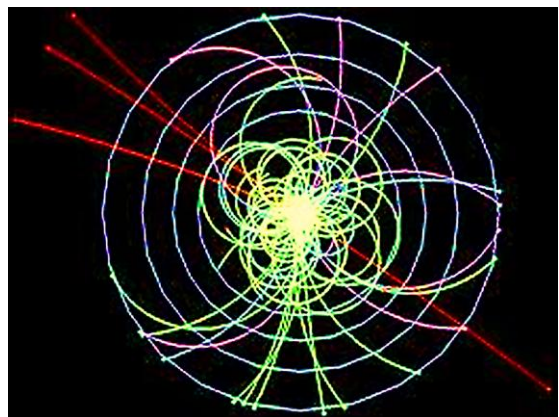

A DYNAMIC IMAGE of Dynamic Events.

MY THEORY

SHAPES-IN-PHASE

Evolution of Plane Regular Shapes starts with their **Polygons**. The **Polygram** is derived from the repeated extensions of the sides of the internal Polygon.

On this journey of extension many significant elements of the formative development of the final Polygram are visibly portrayed.

Shapes in Phase appear to have their origins in various different shape element configurations:

- Some seem to be the final extensions of the sides of Plane Regular Shapes.
- Some seem to evolve **from** Plane Regular **Shapes in phase**.
- Others seem to evolve **into** Plane Regular **Shapes in phase**.
- Others seem to develop **from** a single Plane Regular Shape that evolves **into** Plane Regular **Shapes in phase** that in turn evolve **into** a single Plane Regular Shape again.

Jenny's 12 point star.
Turing's Morphogenesis

Shapes Expanding from inside to outside:

- 1 TWELVE POINT POLYGON = 12
- 2 **HEXAGONS** IN PHASE 2 X 6 = 12
- 3 SQUARES IN PHASE 3 X 4 = 12
- 4 EQUILATERAL TRIANGLES IN PHASE . . . = 12
- 1 TWELVE POINT POLYGRAM = 12

MORPHOGENESIS?

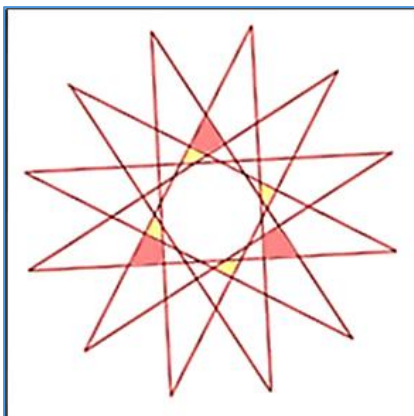

COMPLEX SIMPLICITY?

Or is it **SIMPLE COMPLEXITY?**

CURRENT SCIENCE

ENTANGLEMENT

?

AI Overview of A Hexagon

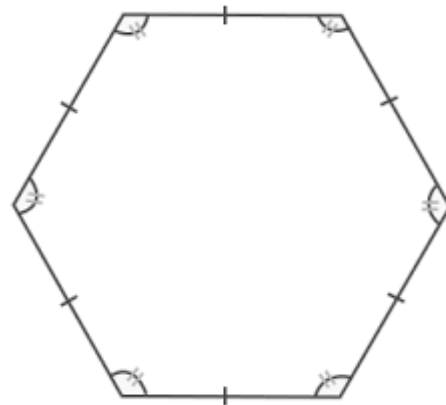

"A hexagon is a six-sided polygon with six interior angles that always add up to 720°"

"A **regular hexagon** has six equal sides and six equal 120° interior angles, and it is the most efficient regular polygon for tiling and enclosing the largest area for a given perimeter. Examples of hexagons can be found in nature and everyday objects, such as a honeycomb or a football."

Website:

What Is a Hexagon? A Guide for Primary Teachers

Teach Starter

<https://www.teachstarter.com › blog › hexagons-definition>

"30 Aug 2023 — A **hexagon** is a two-dimensional shape with six sides and six angles. That also means that hexagons are polygons."

"A **hexagon** can be defined as a closed two-dimensional polygon with six sides. **Hexagon** has 6 vertices and 6 angles also. **Hexa** means six and **gonia** means angles."

MY THEORY

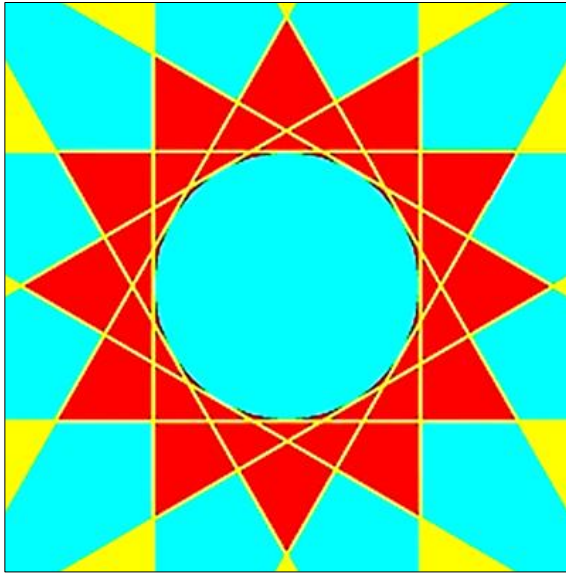

The consequence of continually extending the sides of the shapes that geometrically **morph** from a 12 sided polygon.

1 TWELVE SIDED POLY**GON** = 12

Which expands & morphs into

2 HEXAGONS IN PHASE 2 X 6 = 12

Which expand & morph into

3 SQUARES IN PHASE 3 X 4 = 12

Which expand & morph into

4 EQUILATERAL TRIANGLES IN PHASE . . = 12

Which expand & morph into

1 TWELVE POINT POLY**GRAM** = 12

*Which expands & morphs into
Parallel lines that radiate into Space.*

A SHAPESHIFTER?

Now if I can just find a Genome of Shape that resonates and correlates Graphically and/or Mathematically with Atomic Mass and/or Weight . . .

SUPERSYMMETRY?

CURRENT SCIENCE

MORPHOGENESIS

Alan Turing

Morphogenesis is the biological process that gives cells, tissues, and organisms their shape. It's a fundamental aspect of biology, along with tissue growth control and cellular differentiation patterning.

Morphogenesis involves a series of processes that are driven by cell mechanics, including:

- **Bending or invagination:** Creates tissue deformations that are out-of-plane
- **Tissue flow and extension:** Includes planar expansion and rotational flows
- **Hollowing:** Forms internal fluid-filled lumens within a tissue
- **Tissue branching:** Creates 3D arborization

What was Turing's theory?

Turing's groundbreaking theory of computational universality unveiled the remarkable notion that a single machine — the Turing machine — could emulate any other machine or computational procedure. It's like having a magical device that can transform into any tool you need, capable of solving a multitude of problems. 11 May 2023

Morphogenesis is the *biological* process that causes cells, tissues, or organisms to develop their shape. It's one of the fundamental aspects of developmental biology.

MY THEORY

The 2 dimensional Shape Ratios

My theory is based on the *Shape Ratios* of 2 dimensional Plane Regular Shape.

These Ratios are calculated by dividing the dimensions of the Circumscribing Circle of a shape by the dimensions of its Inscribing Circle.

The Radius of each Circle has a **Finite** measure
BUT

When one radius is divided by the other, the resulting Ratio is usually **Infinite**, so embrace this Infinity do not fight it.

Is this an example for Hilbert's Finite/Infinite Quandary?

Finite shapes from Infinite Ratios.

MY INNER CIRCLE OF HARMONY

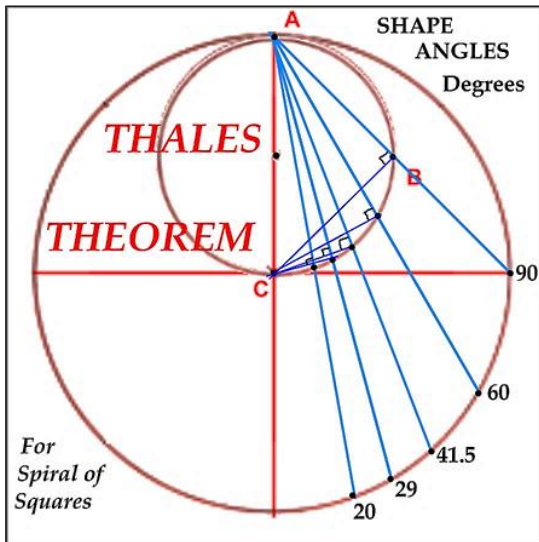

Incorporating Thales Theorem?

| <u>DEGREES</u> | <u>RATIO</u> | <u>BEING</u> |
|-------------------|--------------|----------------|
| 90 ⁰ | 1.414213562 | √2 |
| 60 ⁰ | 2.000000000 | √2x√2 |
| 41.5 ⁰ | 2.828427125 | √2x√2x√2 |
| 29 ⁰ | 4.000000000 | √2x√2x√2x√2 |
| 20 ⁰ | 5.656854249 | √2x√2x√2x√2x√2 |

| <u>BEING</u> | <u>SHAPE</u> |
|----------------|----------------------|
| √2 | SQUARE |
| √2x√2 | EQUILATERAL TRIANGLE |
| √2x√2x√2 | 13 PT. POLYGRAM |
| √2x√2x√2x√2 | 31 PT. POLYGRAM |
| √2x√2x√2x√2x√2 | NONOGRAM |

CURRENT NUCLEAR SCIENCE

The holographic principle

"A way to reconcile quantum mechanics with the theory of relativity"

"The holographic principle is a theory in physics, rooted in string theory and quantum gravity, that suggests **the description of a volume of space can be encoded on a lower-dimensional boundary**, like a 'hologram'."

"It posits that the maximum amount of information within any region of space is limited by its **surface area**, not its **volume**, a concept derived from black hole thermodynamics."

"In theoretical physics, **compactification** means changing a theory with respect to one of its space-time dimensions. Instead of having a theory with this dimension being **infinite**, one changes the theory so that this dimension has a **finite** length, and may also be periodic."

"The **holographic principle** is a property of string theories and **a supposed property of quantum gravity** that states that the description of a **volume** of space can be thought of as **encoded on a lower-dimensional boundary to the region** – such as a light-like boundary like a gravitational horizon."

MY THEORY

SHAPES IN PHASE

DIATOMS

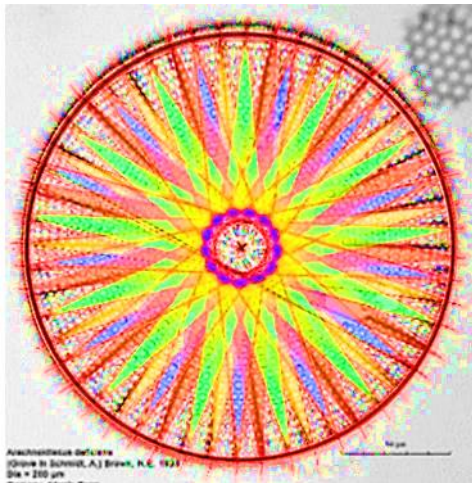

Diatom:

13pt Polygram In phase with itself **four** times.
All derived from and sharing the same ratio.

A shape can be in **quantum superposition** where it behaves as though it is **simultaneously** here

... and there.

... and there.

... and there.

'existing in multiple states at once until measured'

SHAPE RATIO for this 13pt Polygram:

$$\begin{aligned} & \sqrt{2} \times \sqrt{2} \times \sqrt{2} \times \sqrt{2} \times \sqrt{2} \times \sqrt{2} \\ & = 8.0000000000000000. \end{aligned}$$

Quantum mechanics:

In my theory:

'Physical Size is irrelevant'.

Can Diatoms be described as "**tiny objects**"?
My research indicates that Diatoms require SEM Microscopes to see them and yet they display:

- ❖ Plane Regular Shapes
- ❖ Shapes-in-Phase
- ❖ Prime Numbered Shapes
- ❖ Prime Shapes-in-Phase
- ❖ Du Sautoy's "Prime Shapes in Nature"
- ❖ Shape Theory millions of years old.

CURRENT NUCLEAR SCIENCE

QUANTUM SUPERPOSITION

THE TWO GOLDEN RULES OF QUANTUM MECHANICS

Rule 1: A particle can be in **quantum superposition** where it behaves as though it is **both** here and there.

Rule 2: When measured, the particle will be found **either** here or there.

Many phenomena predicted by quantum mechanics can be understood using these two simple rules.

WHAT ARE THE SIX LAWS OF QUANTUM PHYSICS?

We propose six principles as fundamental principles of quantum mechanics:

Principle of space and time,
Galilean principle of relativity,
Hamilton's principle,
Wave principle,
Probability principle,
and

Principle of Indestructibility and
Increatability of particles.

30 Aug 2005

"**Quantum mechanics** is the physics that describes how the universe works on the smallest scales, like atoms and subatomic particles."

"Instead of following the predictable rules of our everyday world, **tiny objects** behave strangely, exhibiting both

particle and wave-like properties

and existing in multiple states at once until measured."

MY THEORY
'MATHEMATICAL' HARMONICS

Of Shapes that form between the intersections of the
 'Construction' lines:

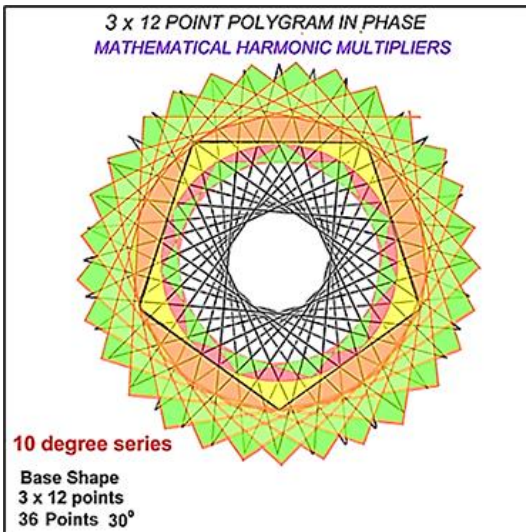

Hidden Circumscribing and Inscribing Circles for the hidden unseen **Mathematical Shapes** contained within the outlined 'Construction' shapes.

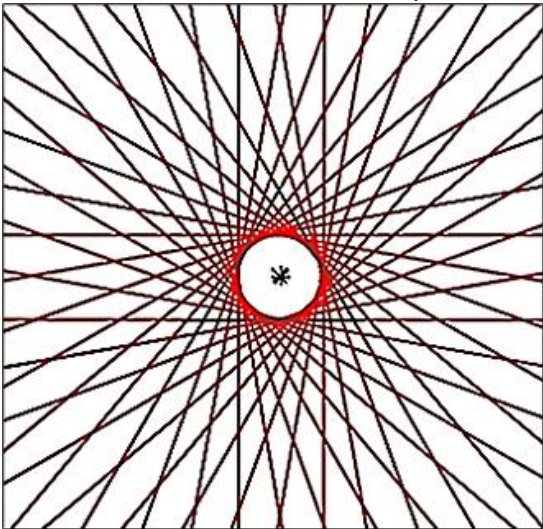

The product of the multiplication of the ratios for all these 'Mathematical' Shapes will produce the **Mathematical (and Graphical)** ratio for the overall shape.

I have titled them 'Mathematical' as they can be seen to contribute to the Mathematical Ratio of the Outer shape without also contributing to the Outer shape's Graphics. They are a product of the Outer Shape's Construction lines and only exist because of the Outer Shape's Construction lines.

CURRENT NUCLEAR SCIENCE
'A MORE UNIVERSAL THEORY'

SUPERPOSITION

General relativity is a classical theory, meaning that **space-time** takes on one, and only one, **shape** at every moment.

In contrast, **matter** is **quantum mechanical**, meaning it can have multiple possible states at once—a feature known as **superposition**.

Since **space-time** reacts to the matter in it, theorists expect that any matter particles in a superposition of occupying two different locations should force space-time into a superposition of two distortions. That is, **space-time and gravity should also follow quantum rules**.

- But physicists haven't yet worked out what those rules are.

Principle of Superposition, in wave motion, the principle that when two or more waves overlap in space, the resulting disturbance is equal to the algebraic sum of the individual disturbances. This principle holds for many different kinds of waves, such as waves in water, sound waves, and electromagnetic waves.

"Because of the principle of superposition, the old saying that

'no two things can occupy the same space at the same time'

does not apply to waves.

'Indeed, an infinite number of waves can occupy the same space at the same time.

Furthermore, they do this without affecting one another, so that each wave retains its own character **independent of how many other waves are present at the same point and time.**'

MY THEORY

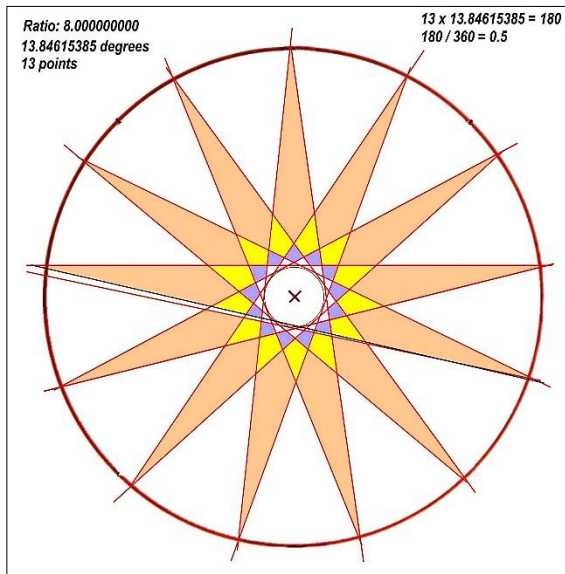

Plane Regular Shape Theory

2 is my ratio for an Equilateral Triangle
= 2.000000000

√2 is my ratio for a Square
= 1.414213562

"Shape x Shape = Shape"

2√2 = An Equilateral Triangle x A Square
= 2.000000000 x 1.414213562 = 2.828427124
= a 13 point polygram.

2√2

Graphically & Mathematically

√2 AND SHAPE THEORY:

| <u>DEGREES</u> | <u>RATIO</u> | <u>BEING</u> |
|-----------------------|---------------------|---------------------|
| 90° | 1.414213562 | √2 |
| 60° | 2.000000000 | √2x√2 |
| 41.5° | 2.828427125 | √2x√2x√2 |
| 29° | 4.000000000 | √2x√2x√2x√2 |
| 20° | 5.656854249 | √2x√2x√2x√2x√2 |
| 13.84615385° | 8.000000000 | √2x√2x√2x√2x√2x√2 |

BEING

- √2
- √2x√2
- √2x√2x√2**
- √2x√2x√2x√2
- √2x√2x√2x√2x√2
- √2x√2x√2x√2x√2x√2

SHAPE

- SQUARE
- EQUILATERAL TRIANGLE
- 13 PT. POLYGRAM**
- 31 PT. POLYGRAM
- NONOGRAM
- 13 PT. POLYGRAM

CURRENT NUCLEAR SCIENCE

**Did Quantum Theory
Need to Be Modified?**

"It took until the 1960s before there were any clues to an answer.

John Bell, a brilliant Irish physicist who did not live to receive the Nobel Prize, devised a scheme to test whether the **notion of hidden variables** made sense."

"**Bell produced an equation** now known as **Bell's inequality** that is always correct — and only correct — for hidden variable theories, and not always for quantum mechanics. Thus, if Bell's equation was found not to be satisfied in a real-world experiment, local hidden variable theories can be ruled out as an explanation for quantum entanglement."

NOTE THE **2√2** NOTATION ON HIS BLACKBOARD!
ALSO HIS 'GREATER THAN OR EQUAL TO' **2**.

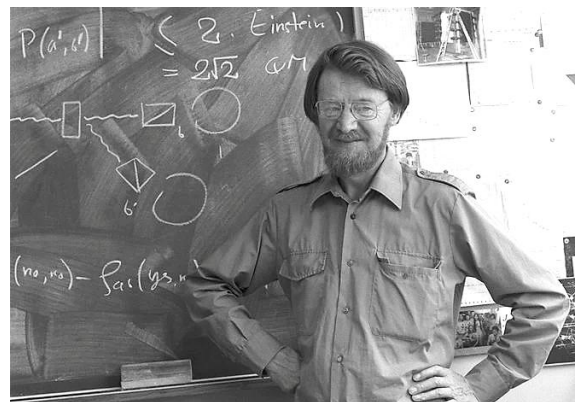

MY THEORY

Physical size is irrelevant to Plane Regular Shape Ratios. A shape the size of a thimble will have the same Ratio as the same shape the size of the Universe (or Jupiter or Saturn).

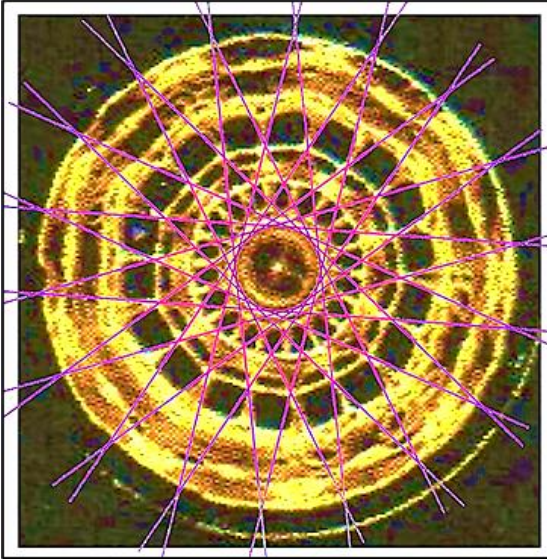

Please note how the shapes' sides as they pass from the Inscribing Circle to the Apex cross over the construction lines of other sides of the shape and where they cross over they seem to indicate a circular feature of the shape.

"Each pair of circles can produce a shape; a 'Mathematical' Shape."

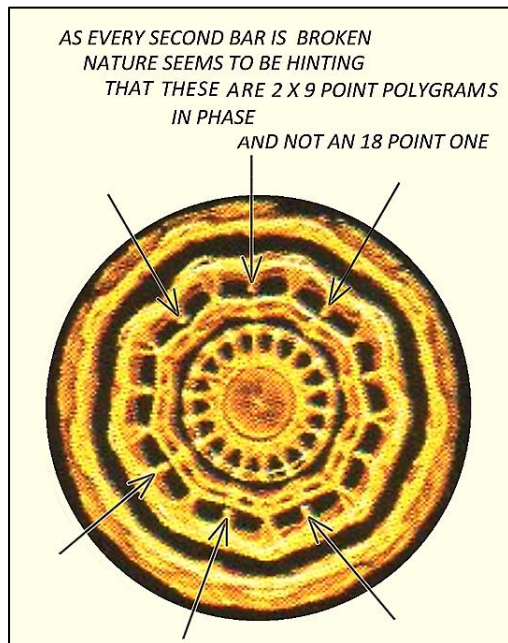

Shapes in Phase seem to reflect concepts seen in **Entanglement**

CURRENT NUCLEAR SCIENCE

'Many aspects of **quantum mechanics** yield unexpected results, defying expectations and deemed counterintuitive. These aspects can seem paradoxical as they map behaviours quite differently from those seen at larger scales.' In the words of quantum physicist Richard Feynman, quantum mechanics deals with nature as "She is—absurd".^[4]

'Features of quantum mechanics often defy the simple explanations in everyday language.'

'One example of this is the **uncertainty principle**: precise measurements of **position** cannot be combined with precise measurements of **velocity**.

Another example is **entanglement**:

A measurement made on one particle (such as an electron that is measured to have spin 'up') will correlate with a measurement on a second particle (an electron will be found to have spin 'down') **if the two particles have a shared history.**'

'This will apply even if it is impossible for the result of the first measurement to have been transmitted to the second particle before the second measurement takes place.'

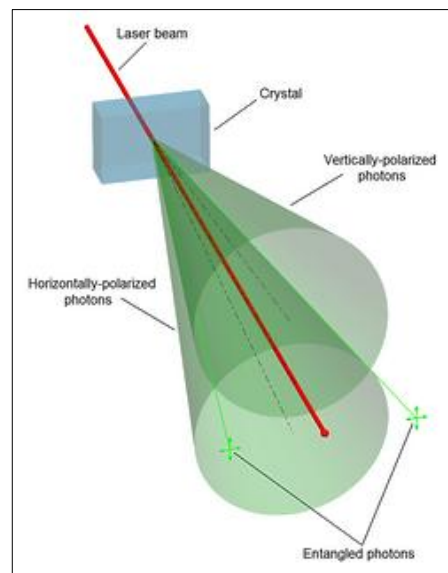

MY THEORY

Cymatics in 18th 19th and 20th centuries.

Michael Faraday recognised the similarity between the properties of **electricity** and the shape forming waves in **cymatics** experiments.

MY SUPERSYMMETRY

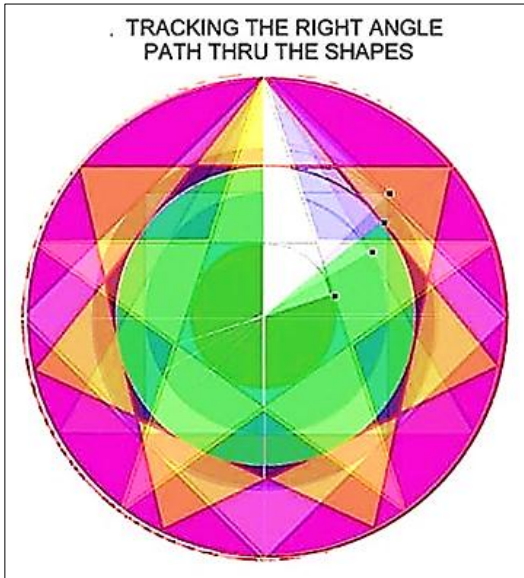

Marking the points where the various Inscribing Circles of the shapes intersect the Inner Circle of Harmony.

MY INNER CIRCLE OF HARMONY

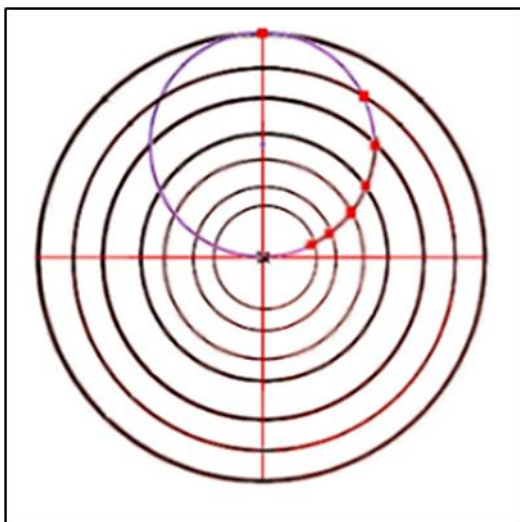

Marking the points where the various Inscribing Circles of the shapes intersect the Inner Circle of Harmony.

CURRENT NUCLEAR SCIENCE

History of quantum mechanics

"James C. Maxwell's unification of the equations governing **electricity, magnetism, and light** in the late 19th century led to experiments on the interaction of light and matter."^[5]

What are the forces that govern their interactions?

"The Standard Model also describes the fundamental forces of Nature and how they act between fundamental particles. Possible discoveries at the LHC could validate models, such as those incorporating **Supersymmetry**, where the forces unify at very high energies".

CERN'S SUPERSYMMETRY

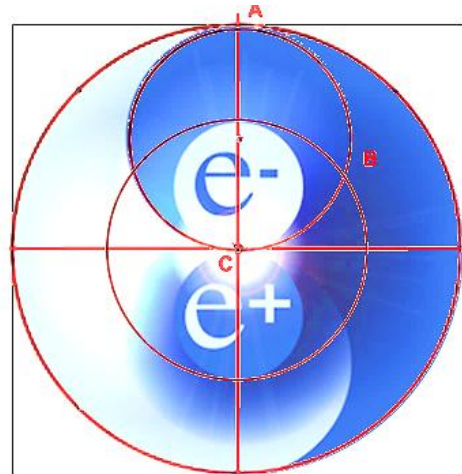

MY THEORY

MY SINGULARITY:

Outer Circle / Inner Circle = 1.

Outer Circle = Inner Circle

**SHAPE FORMATION USING
MY INNER CIRCLE OF HARMONY**

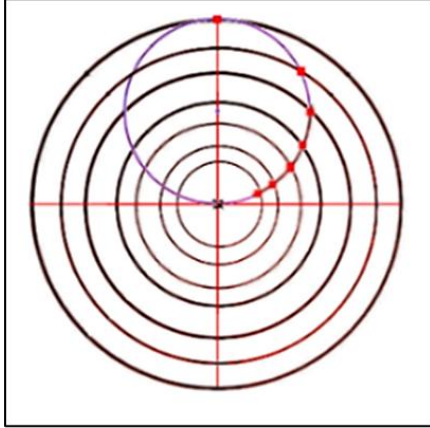

ALIGNMENT ATTEMPTS

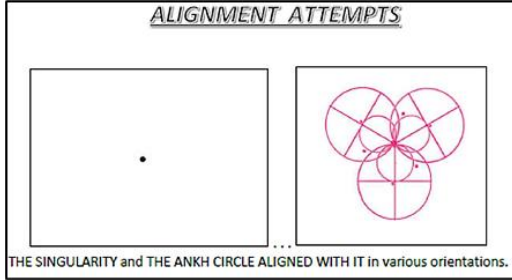

**CERN'S STANDARD MODEL
& 'MY CIRCLE OF INNER HARMONY'**

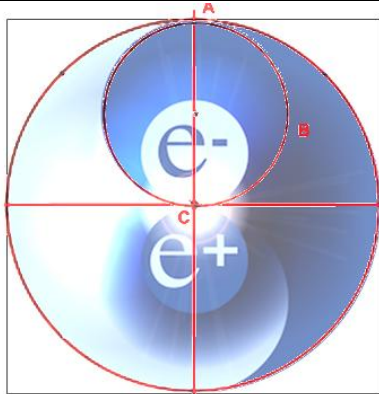

I was amazed at how much the CERN Image titled 'The Standard Model' had in common with my image for a Harmonic Mechanism for the production of shape.

Finally, I can relate Einstein's $e = mc^2$ to shape. There it is in "Cern's Standard Model" logo.

CURRENT NUCLEAR SCIENCE

THE SINGULARITY

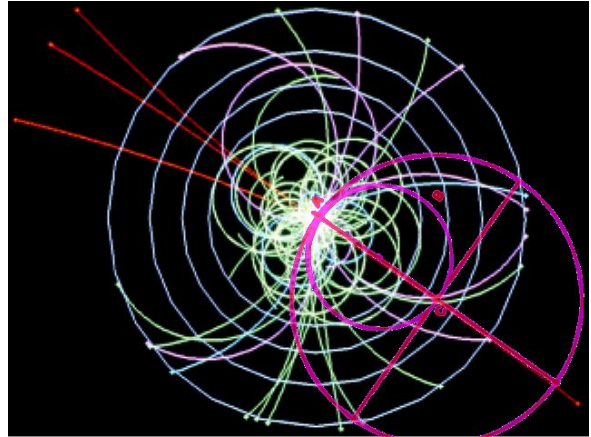

ALIGNING MY SINGULARITY WITH CERN'S:
(My Singularity is at My point A)

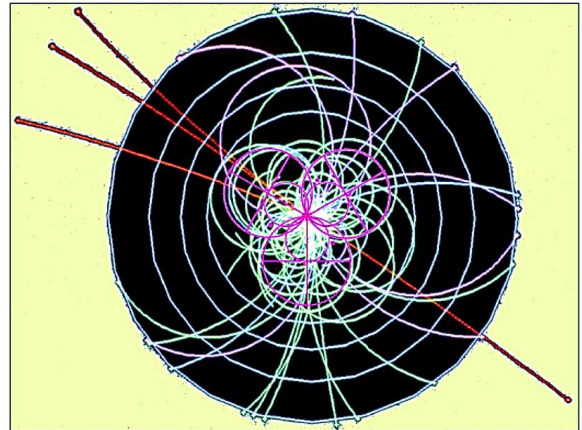

WITH SOME SHAPE ANGLES INCLUDED:

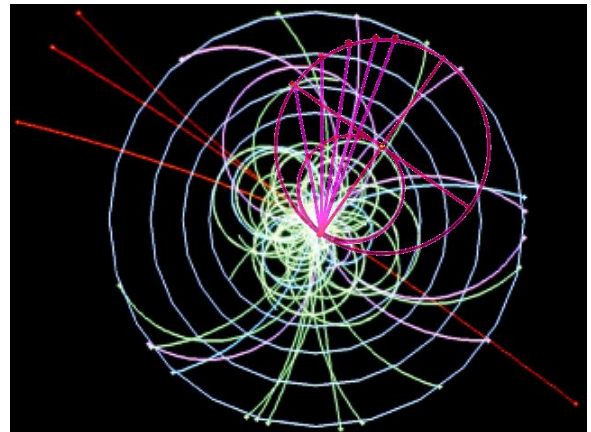

MY THEORY

As **B** approaches **A**

As **B** approaches **A** (in Anti - Clockwise manner) in my theory, the Shape Ratios are descending. If **B** persists in this direction the Shape Ratios approach 1.000000000, my Singularity.

(at **A**), (Inner Circle = Outer Circle).
(Shape Ratio = Outer Circle / Inner Circle)
(at **A** Shape Ratio = 1)

$$\text{Ratio } 1 / 1 = 1$$

Below 1.000000000 (A anticlockwise to C).

My Matrix results indicate the prospect of ratios of **reciprocal value** to those that formed shapes above 1.000000000.

So, to enter the hemisphere to the left of the diameter **AC** one has to travel anti-clockwise past the singularity where the ratio is 1.000000000. So, that hemisphere is full of reciprocal values; perhaps dark or anti matter.

MY INNER CIRCLE OF HARMONY

Clockwise will only take one towards Infinity.

Anti-clockwise will only take one towards and past the Singularity (Into Dark Matter?).

Some choice . . . Infinity or the Singularity.

*Our lifestyle exists **between** Infinity and the Singularity*

Travelling anti-clockwise will only take one to the **Singularity** and beyond and thus to the shapes formed by the reciprocal values, possibly our original Regular Shapes but inside out.
(Refer Moellering & Rayner 1980).

Physical size is irrelevant to Plane Regular Shape Ratios.

A shape the size of a thimble will have the same Ratio as the same shape the size of the Universe.

CURRENT NUCLEAR SCIENCE

Cern's Logo with my Circle of Inner Harmony overlaid:

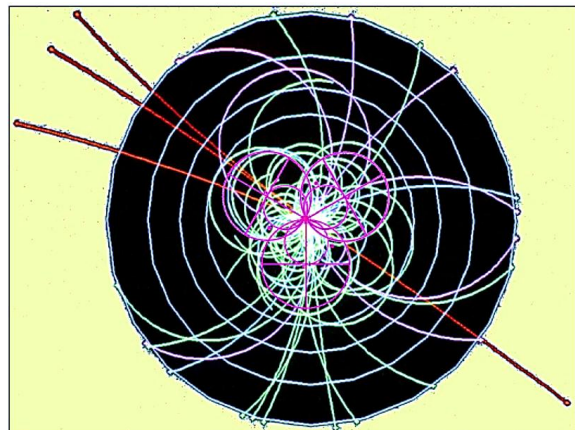
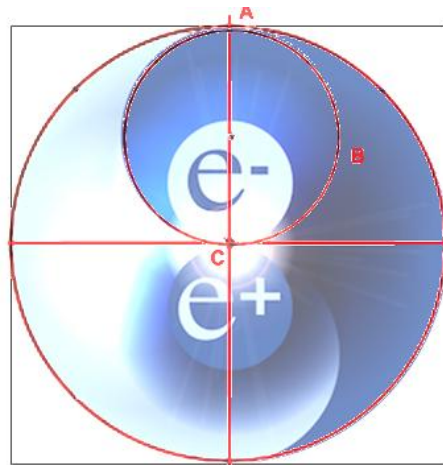

CERN'S SINGULARITY and THE ANKH CIRCLE'S SINGULARITIES aligned with it in various orientations

Moellering & Rayner 1980
Shapes turning Inside Out:



(The circles added to these images are mine)
Red = Outer Circle . . . Blue = Inner Circle
Inner becomes Outer and vice-versa,
Outer becomes Inner.

MY THEORY

AT THE EVENT HORIZON:
 Moellering, H., and J. N. Rayner (1980).

THE **RED** OUTER CIRCLE
 BECOMES THE **RED** INNER CIRCLE
But the Apex Angles are still connected'

THE **BLUE** INNER CIRCLE
 BECOMES THE **BLUE** OUTER CIRCLE
But the Shape's Sides are still connected'

SHAPE IS TURNED INSIDE OUT.

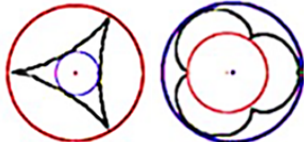
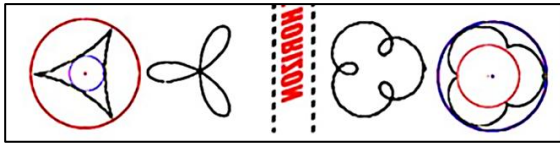

SHAPE IS TURNED INSIDE OUT.

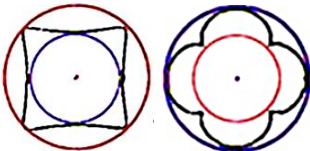
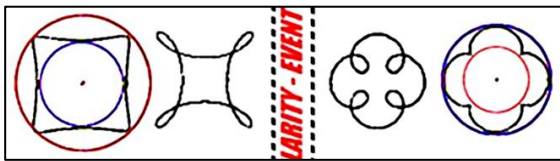

SHAPE IS TURNED INSIDE OUT.

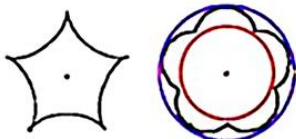
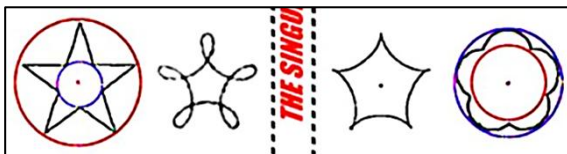

SHAPE IS TURNED INSIDE OUT.

A Shape's Ratio was calculated by dividing its Circumscribing Circle by its Inscribing Circle.

A Shape's Ratio is now its reciprocal.

DARK MATTER?

CURRENT NUCLEAR SCIENCE
(& OTHER SCIENCE)

What is dark matter?

Moellering, H., and J. N. Rayner (1980).
 "A Review of Shape Analysis in the Spatial Sciences."

AT THE EVENT HORIZON:
 IF THE STRONG FORCE BECOMES THE WEAK AND VICE VERSA
 THE **RED** OUTER CIRCLE BECOMES THE **RED** INNER CIRCLE.
 THE **BLUE** INNER CIRCLE BECOMES THE **BLUE** OUTER CIRCLE.
 SHAPE IS TURNED INSIDE OUT.

MY THEORY

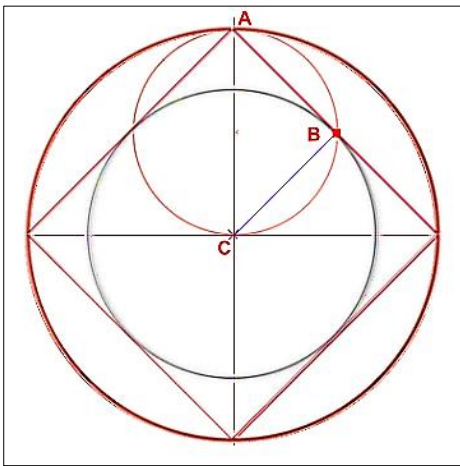

MY IMAGE OF A SQUARE'S CONCEPTION IN 'THE CIRCLE OF INNER HARMONY'

"The dot marked **B** on the circumference of this **Circle of Harmony** marks

- the point where this circle intersects the **Inscribing Circle** of the Shape

AND

- the point where the radius of the Inscribing Circle meets & bisects the **side** of the shape."

AND

- It was also found to be the point where this radius formed a **right angle** with the shape's side.

(A busy **B**).

ALIGNING MY SINGULARITY WITH CERN'S:

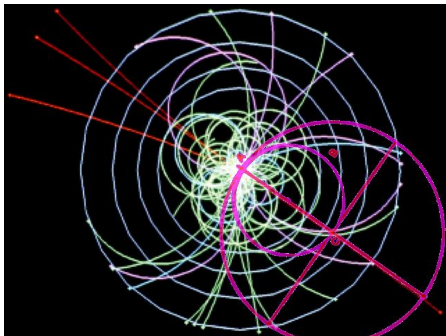

WITH SHAPE ANGLES INCLUDED:

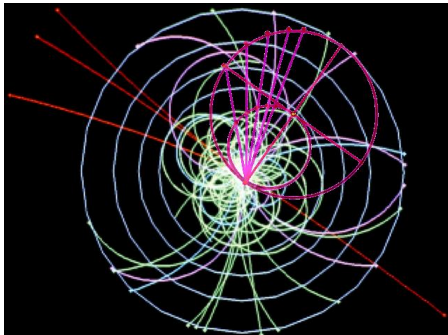

CURRENT NUCLEAR SCIENCE

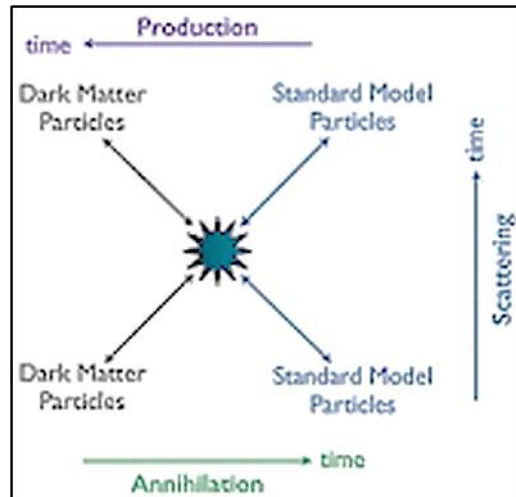

CERN

What is dark matter?

'They think something we have yet to detect directly is giving these galaxies extra mass, generating the extra gravity they need to stay intact. This strange and unknown matter was called "dark matter" since it is not visible.'

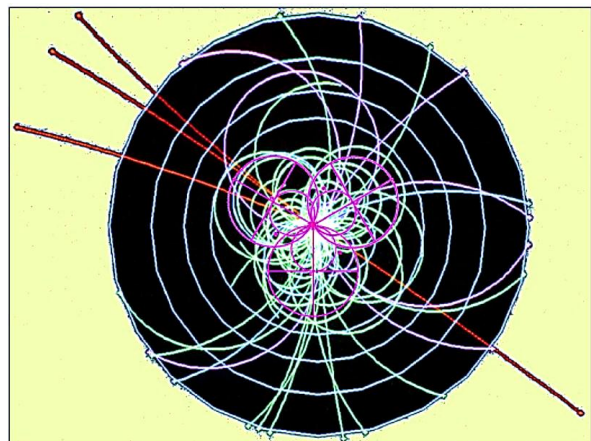

CERN'S SINGULARITY and THE ANKH CIRCLE'S SINGULARITIES aligned with it in various orientations

MY THEORY

As **B** approaches **A** (in Anti - Clockwise manner) in my theory, the Shape Ratios are descending. If **B** persists in this direction the Shape Ratios approach 1.000000000, :- my Singularity.

(at **A**), (Inner Circle = Outer Circle).

Ratio Outer / Inner =1

Below 1.000000000 (**A** anticlockwise to **C**) my Matrix results indicate the prospect of ratios of **reciprocal value** to those that formed shapes above 1.000000000.

With tongue in cheek, I have called these "reciprocal ratios" **Dark Matter** for want of a better more-informed name.

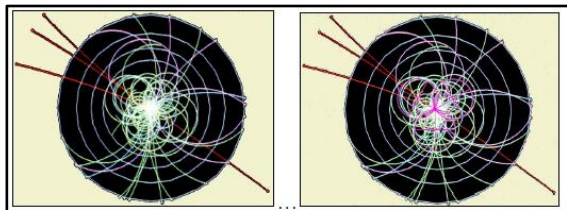
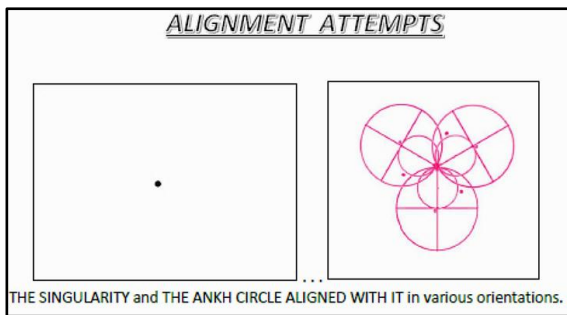

CERN's SINGULARITY and THE ANKH CIRCLE ALIGNED WITH IT in various orientations

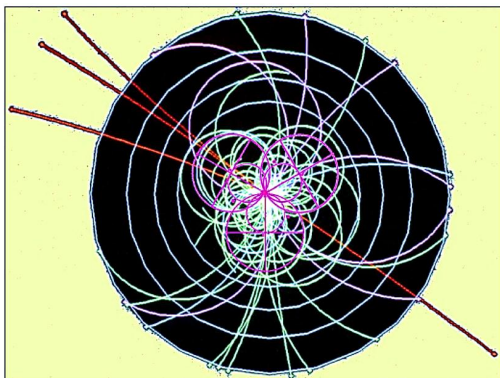

CURRENT NUCLEAR SCIENCE

What is dark matter?

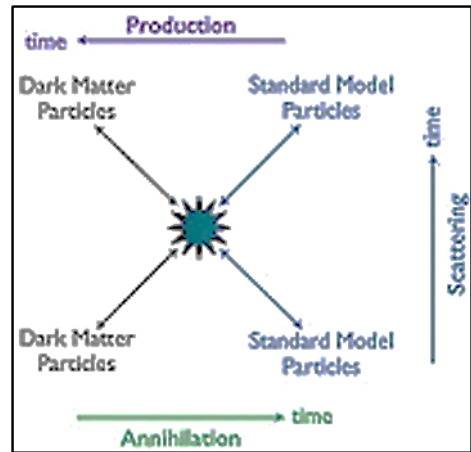

Who are the candidates for dark matter?

Because of its relatively **inert nature**, the physical makeup of dark matter remains a mystery. Perhaps the most likely candidate is the Weakly Interacting Massive Particles (WIMP), though axions and more exotic candidates exist.

DO WE HAVE AGREEMENT AT THIS POINT?

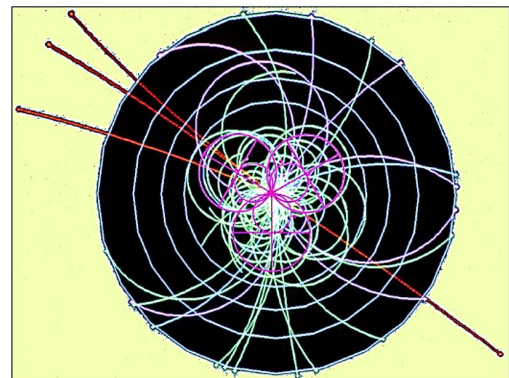

MY THEORY

Below 1.000000000 (A anticlockwise to C) my Matrix results indicate the prospect of ratios of **reciprocal value** to those that formed shapes above 1.000000000.

With tongue in cheek, I call these reciprocal ratios **Dark Matter** for want of a better name.

These ratios still have 'Shape' coding within them but they are less than 1.0000000. They are 'inside out'.

RECIPROCAL SHAPE RATIOS

Below the singularity, shape ratios still exist but now have the reciprocal values to those they once held.

2 becomes 1/2

3 becomes 1/3

4 becomes 1/4

With **reciprocal values**, a previously normal 'multiplication' Matrix will result in ratios of **ever smaller** value.

$3 \times 4 = 12$

$1/3 \times 1/4 = 1/12 \dots$ **reciprocals**

Dark Matter? **Matter's minute coding?**

But, if we can find a **Division Matrix**, we may possibly escape this Black Hole.

$1/4 / 1/3 = 1.333333333$

Becoming matter again?

We know that Shape \times Shape = Shape
and that Shape $/$ Shape = Shape.

In this theory Dark Matter still has the **coding** of matter but it now has a **reciprocal value**. If it keeps reacting in a "Multiplication" fashion the resulting reciprocal shape ratios get ever smaller and smaller until they nearly but never disappear inside this hole. The concept that is 'Infinity' prohibits this disappearance.

Physical size is irrelevant to Plane Regular Shape Ratios. A shape the size of a thimble will have the same Ratio as the same shape the size of the Universe;
Or as the same shape if it was at the north or south pole of Saturn or Jupiter.

CURRENT NUCLEAR SCIENCE

EIGENVALUES

The Eigen Theory (ET) establishes that:
The fundamental form of a particle of matter, or simply the particle, is the key to the complete structure of the physical world. The particle is a distribution of points that forms a manifold of its own.

A reciprocal number is the inverse of that number.

(Refer Moellering & Rayner 1980)

Shapes turn inside out.

"By taking the reciprocal twice, we got back to where we started.

To reverse a reciprocal, you take the reciprocal all over again." $1/1/n$

"In a Black Hole we become compressed into smaller and smaller sizes."

Moellering and Rayner in 1980 used an oscilloscope to portray shapes being turned inside-out.

This was below their "Event Horizon"

MY THEORY**MY 'INNER CIRCLE OF HARMONY'**

Revealed by Plane Regular Shape Theory in conjunction with Thales Theorem.

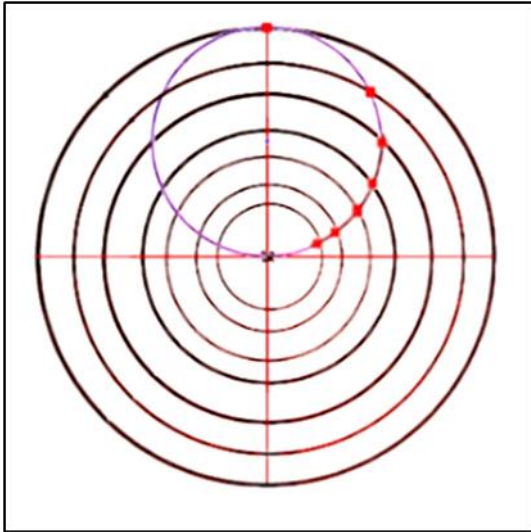

"But, if we can find a Division Matrix, we may possibly escape this Black Hole."

$$1/3 \ / \ 1/4 = 1.333333333$$

= Matter again?

"SHAPE X SHAPE = SHAPE"

Reciprocal or otherwise.

RECIPROCAL SHAPE RATIOS

A Square:

$$\sqrt{2} = 1,414213562$$

A Reciprocal Square (Dark Matter):

$$1/\sqrt{2} = 0.707106781$$

A 'Reciprocal' Square X Equilateral Triangle

$$= 0.707106781 \times 2.000000000$$

$$= 1,414213562 = \sqrt{2}$$

$$= \text{A Square (again)}$$

"SHAPE X SHAPE = SHAPE"

Can we arrange for an Equilateral Triangle to cross over into Dark Matter, remain unchanged, and react with a 'Reciprocal' Square to reform it as a Square?

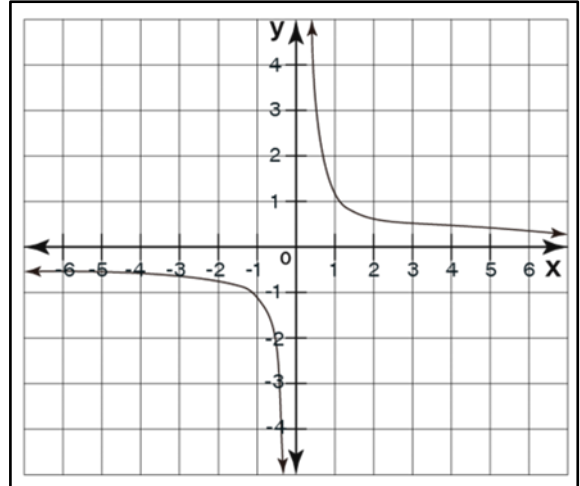
CURRENT NUCLEAR SCIENCE**EIGENVALUES****RECIPROCAL NUMBERS**

"By taking the reciprocal twice, we got back to where we started. To reverse a reciprocal, you take the reciprocal all over again." $1/1/n$

DARK MATTER

"What Is the Inverse of The Reciprocal Equation?"

" $f^{-1}(x)$ is the inverse of the reciprocal equation $f(x)$ ".

"The domain and range of the given function become the range and domain of the reciprocal function."

MY THEORY

SHAPE X SHAPE = SHAPE

CURRENT NUCLEAR SCIENCEBLACK HOLE THERMODYNAMICS

A central player in these developments is the black hole. **Black holes are a consequence of general relativity**, Albert Einstein's 1915 *geometric* theory of gravitation.

In this theory, **gravitation arises from the curvature of spacetime**, which makes objects move as if they were pulled by a force.

Conversely, the curvature is caused by the presence of matter and energy.

According to Einstein's equations, **a sufficiently dense concentration of matter or energy** will curve spacetime so extremely that **it rends, forming a black hole.**

The laws of relativity forbid anything that went into a black hole from coming out again, at least within the classical (**nonquantum**) description of the physics.

The point of no return, called the **event horizon** of the black hole, is of crucial importance.

In the simplest case, the horizon is a sphere, whose surface area is larger for more massive black holes.

It is impossible to determine what is inside a black hole.

"No detailed information can emerge across the horizon and escape into the outside world."

"But, if we can find a **Division Matrix**, we may possibly escape this Black Hole."

$$1/3 / 1/4 = 1.333333333$$

Can some 'Black Hole' interaction equations result in Matter again?

"By taking the reciprocal twice, we got back to where we started. To reverse a reciprocal, you take the reciprocal all over again." $1/1/n$

MY THEORY

*MY POINT A - MY SINGULARITY
WHERE THE CIRCUMSCRIBING CIRCLE
EQUALS THE INSCRIBING CIRCLE.*



My Circles of Harmony have no geometric orientations and so I have arrayed them in various orientations simply to cover the range somewhat.

*MY CIRCLES OF INNER HARMONY ARRAYED
AROUND MY SINGULARITY IN VARIOUS
ORIENTATIONS GIVEN THAT SHAPES HAVE NO
OVERALL GEOGRAPHIC ORIENTATIONS.*

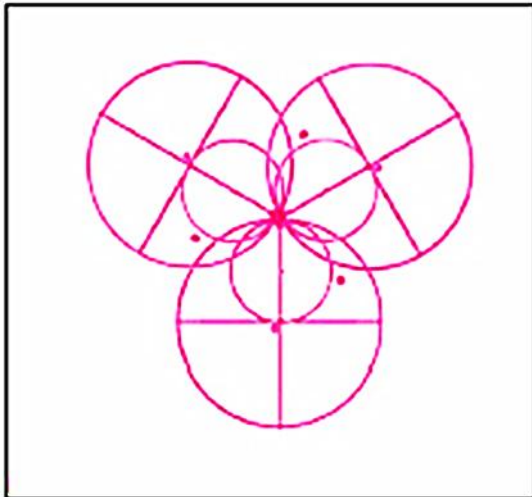

A POINT OF 'SINGULARITY' (somewhere) is common to both Nuclear Theory and my Shape Theory.

Aligning both could possibly indicate any common features of both.

CURRENT NUCLEAR SCIENCE

ATLAS EXPERIMENTS AT CERN

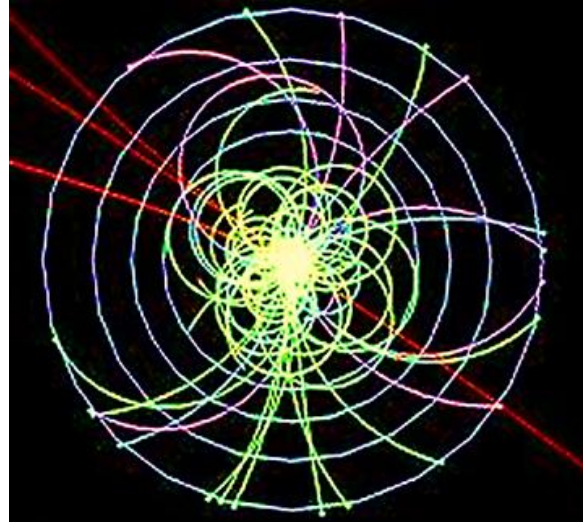

A DYNAMIC IMAGE of Dynamic Events.

*MY CIRCLES OF INNER HARMONY ARRAYED
AROUND CERN'S SINGULARITY IN VARIOUS
ORIENTATIONS GIVEN THAT SHAPES HAVE NO
OVERALL GEOGRAPHIC ORIENTATIONS.*

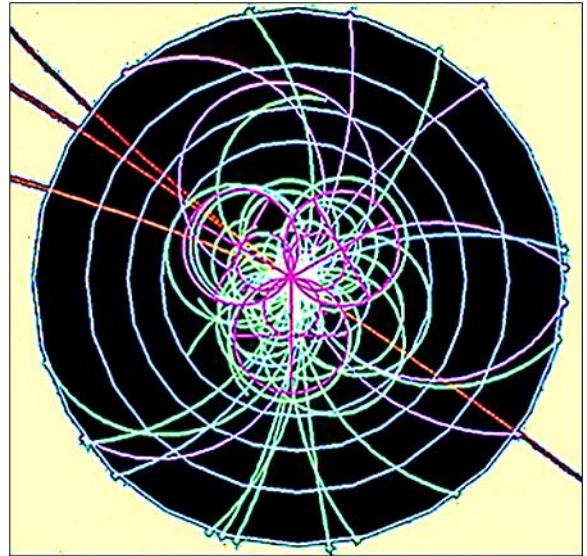

MY THEORY

What are the major types of wave functions
{or particle interactions}?

Shape **X** Shape = Shape

Shape / Shape = Shape

Shape **X** 2 = Shape

(2 is the ratio for a Shape).

Shape / 2 = Shape

(2 is the ratio for a Shape).

Shape² = Shape

(Shape² = Shape x Shape)

√Shape = Shape????

(2 is the ratio for a Shape).

(√2 is the ratio for a Shape).

√ of √2 = 1.189207115

**Shape Ratios are applicable
both Graphically & Mathematically.**

WHAT YOU SEE IS WHAT YOU GET.

CURRENT NUCLEAR SCIENCE

What are the 4 types of particle interactions?

There are four fundamental interactions known to exist:

- gravity,
- electromagnetism,
- weak interaction,
- and strong interaction.

The gravitational and electromagnetic interactions produce long-range forces whose effects can be seen directly in everyday life.

The strong and weak interactions produce forces at subatomic scales and govern nuclear interactions inside atoms.

Some scientists hypothesize that a fifth force might exist, but these hypotheses remain speculative.

SUPERSYMMETRY (SUSY)

'A supersymmetric theory is a theory in which *the equations for force and the equations for matter are identical*.'

'In theoretical and mathematical physics, any theory with this property has the principle of supersymmetry (SUSY).

Dozens of supersymmetric theories exist.'

Supersymmetry

'Supersymmetry is a theoretical framework in physics that suggests the existence of a symmetry between particles with integer spin and particles with half-integer spin.'

'It proposes that for every known particle, there exists a partner particle with different spin properties.'

Source: Wikipedia

'What is supersymmetry in simple terms? Supersymmetry predicts that each of the particles in the Standard Model has a partner with a spin that differs by half of a unit. So bosons are accompanied by fermions and vice versa. Linked to their differences in spin are differences in their collective properties'

MY THEORY**SHAPE TO MUSIC CORRELATION***'Sight and Sound'.***SHAPE TO DIATOMS CORRELATION**

(Centric) Diatoms display Plane Regular Shapes.

SHAPES IN PHASE**DIATOM PRIMES IN PHASE**

Most Centric Diatoms viewed seemed to display:-

Prime numbered Plane Regular Shapes
or

Prime numbered Shapes-in-phase.

RIGHT ANGLES IN PLANE REGULAR SHAPES**PLANE REGULAR SHAPE THEORY****SHAPE TO MUSIC CORRELATION****CURRENT SCIENCE****PLATO'S GLAUCON – 'The Two Harmonies'.***'Sight and Sound'.***DIATOM IDENTIFICATIONS**

Plane Regular Shapes are slowly being associated by diatom researchers (Using their own nomenclature).

ENTANGLEMENT**DU SAUTOY'S 'PRIMES IN NATURE'.**

Du Sautoy states that the only example of 'Primes in Nature' are his cicadas and the timing of their births.

Does he know about **Primes in Phase**?

Are **Primes in Phase** still Primes?

**PLIMPTON 322
THALES THEOREM****STONEHENGE****CYMATICS
DIATOMS
GENOMES**

MY THEORY

SCIAMVS 1 "Mathematical cuneiform tablets in Philadelphia" Tablet 11: N 4942

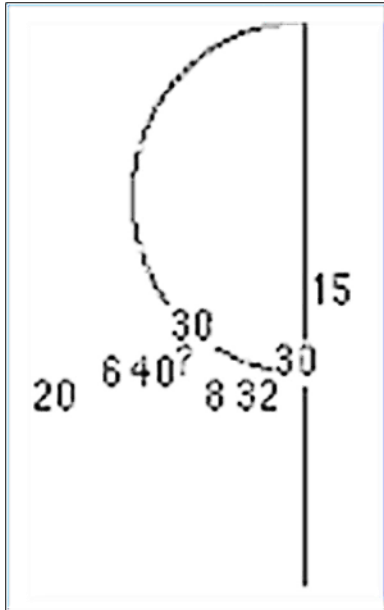

Graphically manipulate this clay tablet image to produce the next image.
 This whole exercise is carried out graphically without the use of Maths. It suggests a method indicated in Plato's Meno.

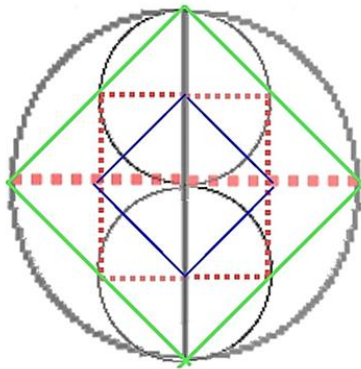

The result remarkably resembles the final image in **BM15285**

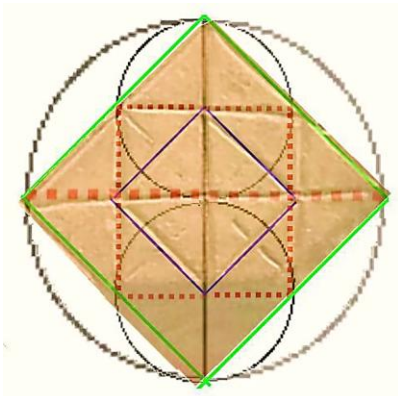

CURRENT SCIENCE

SCIAMVS 1 "Mathematical cuneiform tablets in Philadelphia" Tablet 11: N 4942

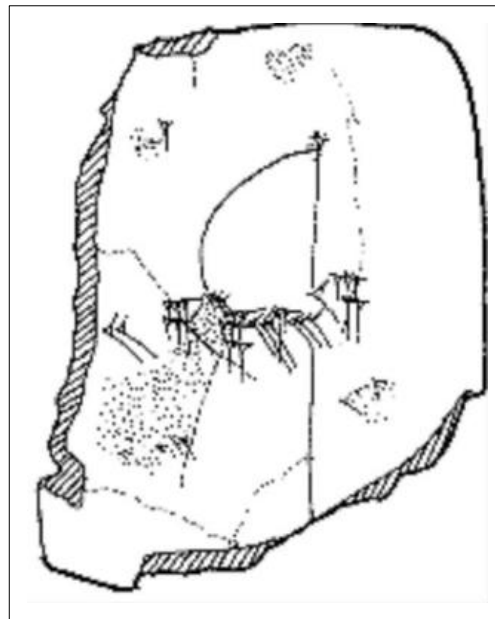

BM15285



MY THEORY

Infinite Ratios form Finite Shapes:

INFINITE AND FINITE TOGETHER:
MY GENOME OF SHAPE

| Deg | Shape | Ratio |
|-----|----------------------------|-------------------|
| 18 | 20pts | 6.472135954999560 |
| 19 | 18.94736842 deg 38pts | 6.111456184000000 |
| 20 | 20 degrees nonogram | 5.656854249492380 |
| 21 | | 5.545084971874640 |
| 22 | 16pts 22.5deg | 5.236067977499790 |
| 23 | | 4.944271909999160 |
| 24 | 24 degrees 30pts | 4.846581983000000 |
| 25 | septagram 25.7142857 | 4.576491223248880 |
| 26 | | 4.321452107803630 |
| 27 | 40pts | 4.236067978000000 |
| 28 | 45pts | 4.176904000000000 |
| 29 | 31pts 29.032258deg | 4.000000000000000 |
| 30 | 12pts | 3.853220324000000 |
| 31 | 29pts 31.03448deg | 3.702459175000000 |
| 32 | 17pts 31.76470588deg | 3.629305232154990 |
| 33 | 33 degrees 120pts | 3.496128197000000 |
| 34 | 34 degrees 37pts | 3.427050986000000 |
| 35 | | 3.464101616000000 |
| 36 | pentagram | 3.236067977499790 |
| 37 | | |
| 38 | | |
| 39 | | |
| 40 | 18pts | 2.936169615 |
| 41 | 13pts 41.53846154deg | 2.828427124746190 |
| 42 | 56pts 41.78571429 | stonehenge |
| 43 | 29pts | 2.772542489 |
| 44 | | 2.618033989000000 |
| 45 | octogram | 2.613125929752760 |
| 46 | | |
| 47 | | |
| 48 | 30pts | 2.472135954999580 |
| 49 | 11pts 49.0909090909 | 2.423290987000000 |
| 50 | 36pts | 2.380952381000000 |
| 51 | | 2.334368543059490 |
| 52 | 52 degrees 45pts | 2.288245610000000 |
| 53 | | |
| 54 | 20pts | 2.212962963000000 |
| 55 | 72pts | 2.180232558000000 |
| 56 | ?? | 2.160726055 |
| 57 | 41pts | 2.118033990000000 |
| 58 | | |
| 59 | | |
| 60 | Equilateral Triangle | 2.000000000000000 |
| 61 | | |
| 62 | | |
| 63 | 40pts | 1.926610162000000 |
| 64 | 64.28571429deg 28pts | 1.907482035000000 |
| 65 | 72pts | 1.888543820000000 |
| 66 | 60pts | 1.851229586000000 |
| 67 | 16pts 67.5deg | 1.847759066000000 |
| 68 | | 1.814652616077490 |
| 69 | 13pts 69.23076923deg | 1.748064098502690 |
| 70 | 35pts | |
| 71 | 33pts 70.909090deg | |
| 72 | 10pts decagram | 1.732050808000000 |
| 73 | | 1.713525493000000 |
| 74 | | |
| 75 | 24pts | 1.650647824000000 |
| 76 | 76 degrees 45pts | |
| 77 | 7pts ϕ 77.14285714deg | 1.618033989000000 |
| 78 | 60pts | 1.572302755514850 |
| 79 | | |
| 80 | 80 degrees 18pts | |
| 81 | 11pts 81.818181deg | 1.527864046000000 |
| 82 | | |
| 83 | | |
| 84 | 84 degrees 15pts | 1.497676197000000 |
| 85 | | |
| 86 | | |
| 87 | 22.5deg series 45pt | 1.448274121000000 |
| 88 | | |
| 89 | | |
| 90 | Square | 1.414213562373100 |

CURRENT SCIENCE

DAVID HILBERT'S

INFINITE AND FINITE TOGETHER

"The program replaces an earlier, unachievable plan of action by the great mathematician David Hilbert, who in 1921 commanded mathematicians to weave infinity completely into the fold of finitistic mathematics."

"Weave infinity completely into the fold of finitistic mathematics."

"Hilbert saw finitistic reducibility as the only remedy for the scepticism then surrounding the new mathematics of the infinite. As Simpson described that era, "There were questions about whether mathematics was going into a twilight zone."

The Rise of Infinity

"The philosophy of infinity that Aristotle set out in the fourth century B.C. reigned virtually unchallenged until 150 years ago. Aristotle accepted "potential infinity" — the promise of the number line (for example) to continue forever — as a perfectly reasonable concept in mathematics. But he rejected as meaningless the notion of "actual infinity," in the sense of a complete set consisting of infinitely many elements."

MY INFINITE RATIOS

My Ratios have been calculated to 15 decimal places. I have found that this number or level of decimals gives me sufficient accuracy in my Finite world.

MY PLANE SHAPE THEORY

MY GRAPHICAL MATHEMATICS

**Pentagon x Pentagon =
Square x Square x Square x Square =
a 31 point Polygram**

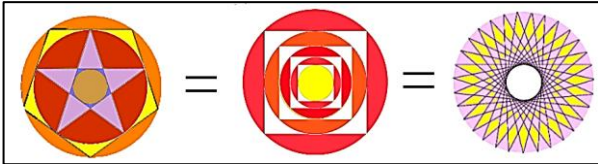

The same Ratio of overall Circumscribing to Inscribing Circles but portraying various components that should graphically and mathematically relate.

Some of Srinivasa Ramanujan's Mathematics:

$$\frac{\{(1 + \sqrt{5}) / 2\}}{3.236067978 / 2.000000000}$$

pentagram / equilateral triangle

Result: 1.618033989 or Inner Septagram or ϕ .

SHAPE THEORY

| | | | |
|------------------------------------|-------------------|----------------|-------|
| ϕ | 1.618033989000000 | 38 degrees | 7pts |
| $\sqrt{2}$ | 1.414213562000000 | 90 degrees | 4pts |
| $\phi \times \sqrt{2}$ | 2.288245610000000 | 52 degrees | 45pts |
| $\phi \times \sqrt{2} \times \phi$ | 3.702459175000000 | 32.14285714deg | 56pts |

SHAPE RATIO TERMINOLOGY IN RAMANUJAN'S EQUATION:

$$\left(\sqrt{\frac{5 + \sqrt{5}}{2}} - \frac{1 + \sqrt{5}}{2} \right)$$

Ramanujan's first element in his equation but, in shape ratio terminology, ϕ

$\{(1 + \sqrt{5}) / 2\} = 1.618033989 = \phi$

$1.618033989 \times 1.618033989 = 2.618033989$

$\phi \times \phi = \phi$

Did Ramanujan know they were Shape Ratios?

RAMANUJAN'S WORKS

'Three Puzzles Inspired by Ramanujan'

"Insights from the mathematical genius Srinivasa Ramanujan give us a number of ways to explore the infinite."

Olena Shmahalo/Quanta Magazine

"Srinivasa Ramanujan's story is part of mathematical folklore, one of the most romantic in the history of mathematics."

"He started as a poor self-taught clerk in India. Working alone, he discovered highly original and unknown mathematical results that were far ahead of his time."

In 1913, he sent a letter filled with **strange-looking mathematical theorems** to G. H. Hardy, a mathematician at the University of Cambridge. Hardy, one of the world's leading experts on number theory, later said that "some of [Ramanujan's theorems] defeated me completely; I had never seen anything in the least like them before."

He was referring to results like the one below.

$$\frac{1}{1 + \frac{e^{-2\pi}}{1 + \frac{e^{-4\pi}}{1 + \frac{e^{-6\pi}}{1 + \frac{e^{-8\pi}}{1 + \frac{e^{-10\pi}}{\dots}}}}}} = \left(\sqrt{\frac{5 + \sqrt{5}}{2}} - \frac{1 + \sqrt{5}}{2} \right) e^{2\pi/5}$$

Pacioli and Fibonacci

$\phi \times \phi = \phi$

The Golden Mean.

Galois

Continued Fractions.

Ramanujan

Continued Fractions.

MY PLANE SHAPE THEORY

SOME OF THE VARIOUS SHAPE RATIOS FOUND IN RAMANUJAN'S EQUATIONS

| | |
|------------------|-------------------|
| $(\sqrt{5}-1)/2$ | 0.618033988749895 |
| $\sqrt{5}/2$ | 1.118033988749890 |
| $\sqrt{5}-1$ | 1.236067977499790 |
| $(\sqrt{5}+1)/2$ | 1.618033988749890 |
| $\sqrt{5}$ | 2.236067977499790 |
| $\sqrt{5}+1$ | 3.236067977499790 |
| $\sqrt{5}+2$ | 4.236067977499790 |
| $\sqrt{5}^2$ | 5.000000000000000 |
| $\sqrt{5}+3$ | 5.236067977499790 |
| $\sqrt{2}$ | 1.414213562373100 |
| Φ^2 | 2.618033988749890 |

| | | | |
|--------------------------|------------------|------------------|-------------------|
| dark matter Φ | ϕ | $(\sqrt{5}-1)/2$ | 0.618033988749895 |
| | not shape ratios | $\sqrt{5}/2$ | 1.118033988749890 |
| pentagon | | $\sqrt{5}-1$ | 1.236067977499790 |
| inner septagram | Φ | $(\sqrt{5}+1)/2$ | 1.618033988749890 |
| | not shape ratios | $\sqrt{5}$ | 2.236067977499790 |
| pentagram | | $\sqrt{5}+1$ | 3.236067977499790 |
| 40pts 27degrees | | $\sqrt{5}+2$ | 4.236067977499790 |
| | not shape ratios | $\sqrt{5}^2$ | 5.000000000000000 |
| 16pts 22.5deg 41pts? | | $\sqrt{5}+3$ | 5.236067977499790 |
| square | | $\sqrt{2}$ | 1.414213562373100 |
| 90pts (from Index No 11) | | Φ^2 | 2.618033988749890 |

$$\left(\sqrt{\frac{5+\sqrt{5}}{2}} - \frac{1+\sqrt{5}}{2} \right)$$

$(1 + \sqrt{5}) / 2 = 1.618033989$

Is the Golden Equation.

Is equal to ϕ .

$1.618033989 \times 1.618033989 = 2.618033989$

$\phi \times \phi$ Is equal to Φ .

CURRENT SCIENCE

ϕ

Φ

| |
|--|
| 1361 / 260 |
| Ratio: 5.236067978 |
| 22.5 degrees (rotated alternatively 22 and 23 degrees) |
| 16 points 22.5 degrees ratio: 5.236067978 |
| 8 points 45 degrees ratio: est. 2.596153846 should be 2.618033989 |
| 16 points 67.5 degrees ratio: est. 1.807692308 |
| 4 points 90 degrees ratio: known to be 1.414213562 but est. 1.415384615 |
| 16 points 112.5 degrees ratio: est. 1.230769231 perhaps 1.236067978? |
| 8 points 135 degrees ratio: est. 1.096153846 |
| 16 sided gon 157.5 degrees ratio: known to be 1.020156458 |

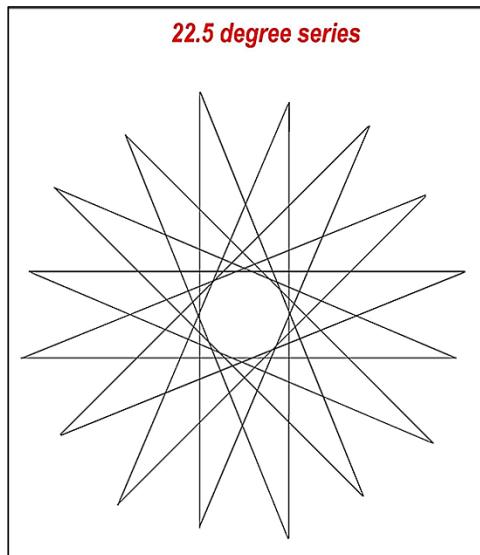

MY PLANE SHAPE THEORY

HARMONICS OF PLANE REGULAR SHAPES AND THEIR INBUILT RIGHT ANGLED TRIANGLES

Re PLATO: "As the basis for all of his calculations, leading up to the construction of 'his number', he uses the Pythagorean triangle".

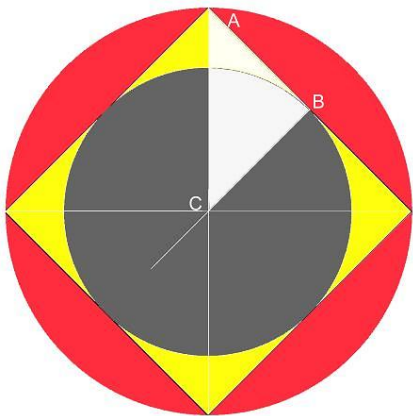

- A to B** *Half the side of the Shape.*
- B to C** *Half the Diameter (Radius) of the Inner Circle.*
- A to C** *Half the Diameter (Radius) of the Outer Circle*

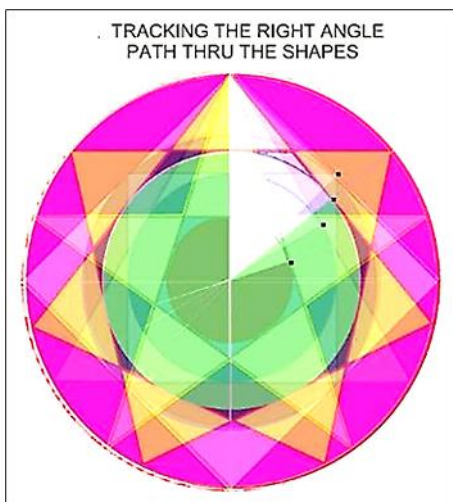

It seems that every Plane Regular Shape has a Right Angled Triangle that is constructed by the component parts of its Shape Ratio. (Circumscribing Circle divided by Inscribing Circle.)

CURRENT SCIENCE

WAVE FUNCTION OF PARTICLES

Particles act like waves.

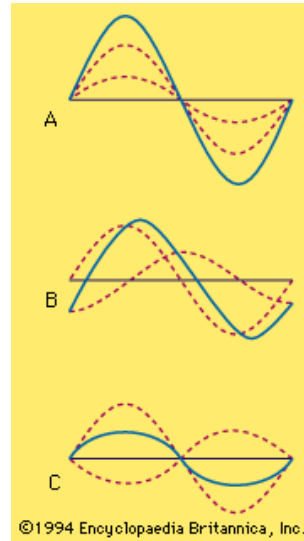

MY THEORY

It seems that every Plane Regular Shape has a Right Angled Triangle that is provided by the component constructing parts of its Shape Ratio. (Circumscribing Circle divided by Inscribing Circle.)

PLYMPTON 322?

Was this ancient tablet applicable here? If it was then it should expand our conceptual boundaries of what should be considered ancient knowledge.

If all Plane Regular Shapes produce Right Angled Triangles does the inverse apply? Do all Right Angled Triangles produce Plane Regular Shapes?

MY PLANE SHAPE THEORY

CURRENT SCIENCE

INDICATING A RIGHT ANGLE IN THE CONSTRUCTION LINES OF EACH SHAPE

SQUARE

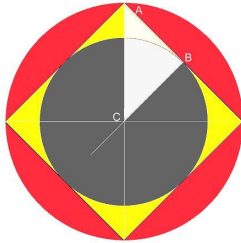

INNER SEPTAGRAM

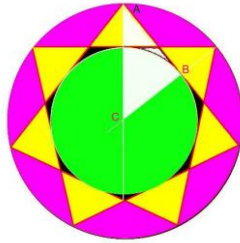

EQUILATERAL TRIANGLE

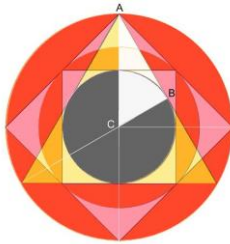

OCTOGRAM

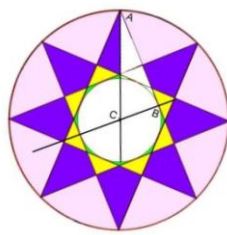

PENTAGRAM

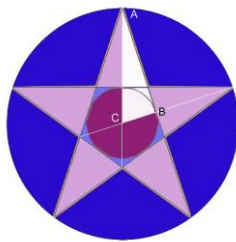

NONOGRAM

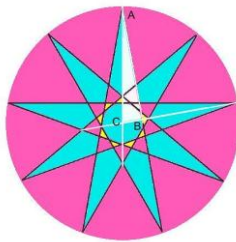

OCTOGON

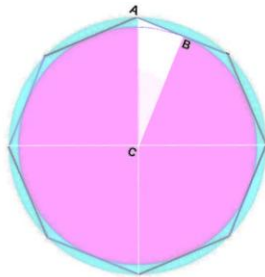

A to B

Half the side of the Shape.

B to C

Half the Diameter (Radius) of the Inner Circle.

A to C

Half the Diameter (Radius) of the Outer Circle

SHAPE RATIOS

IN THESE FEW EXAMPLES WE CAN SEE THE WAY THAT THE RATIOS APPEAR TO ORGANIZE THEMSELVES IN THEIR OWN FORM OF HARMONY.

| <u>SHAPE</u> | <u>RATIO</u> |
|--------------|-------------------|
| SQUARE: | 1.414213562373100 |
| INNER SEPT: | 1.618033988749890 |

| | |
|----------------|-------------------|
| EQUI TRIANGLE: | 2.000000000000000 |
| OCTOGRAM: | 2.613125929752760 |
| PENTAGRAM: | 3.236067977499790 |
| NONOGRAM: | 5.656854249492380 |

THE SIZES OF THE **RATIOS** OF THE SHAPES ARE IN **ASCENDING** ORDER GOING FROM TOP TO BOTTOM.

CONVERSELY:

THE SIZES OF THE **ANGLES** OF THE SHAPES ARE IN **DESCENDING** ORDER GOING FROM TOP TO BOTTOM.

THE **RATIOS** ARE IN INVERSE PROPORTION TO THE **APEX ANGLES**

MY PLANE SHAPE THEORY

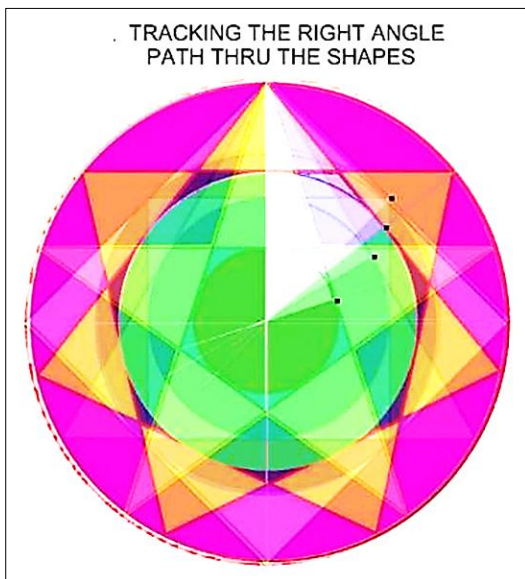

By making the Shape drawings transparent;

And by applying a **Common Circumscribing Circle** to contain all of the shapes;

And by overlaying the now transparent
"Fixed Sized" Shapes and their circles;

Keeping always the vertical alignment such
that point **A** is common to all;

(Noting, that in my shape theory, Point **A** is
allocated the role of "The Singularity".)

Earlier in my research I had learnt that the **ratios** of Plane Regular Shapes bore no association to the overall physical **size** of the shapes. A Square with ratio 1.414213562 and the size of a thimble had the same ratio as a square with ratio 1.414213562 the size of the Universe. And yet **shape ratios**, regardless of the diverse sizes of the shapes could be divided or multiplied to produce a new **shape ratio** that represented another shape both mathematically and graphically, regardless of its size.

And yet a Shape's Ratio is unique to that Shape.

Does this make discussion of Infinity immaterial
within the Theory of Plane Regular Shape?

CURRENT SCIENCE

HEISENBERG UNCERTAINTY PRINCIPLE

The Heisenberg **uncertainty principle** is a fundamental quantum mechanical principle stating that **there's a limit to how precisely certain pairs of physical properties, like a particle's position and momentum (mass in motion), can be known simultaneously.**

The more accurately you know one property, the less accurately you can know the other. This isn't a limitation of measurement tools, but a fundamental characteristic of the universe, stemming from the wave-like nature of particles.

THE PHILOSOPHER'S STONE:

"... point **A** is common to all"
THE GODDESS OF SOVEREIGNTY

MY CIRCLES OF INNER HARMONY ARRAYED
AROUND CERN'S SINGULARITY IN VARIOUS
ORIENTATIONS.

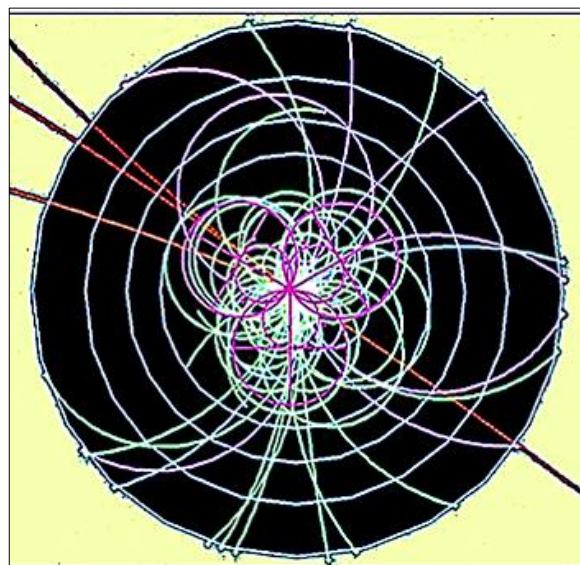

MY PLANE SHAPE THEORY

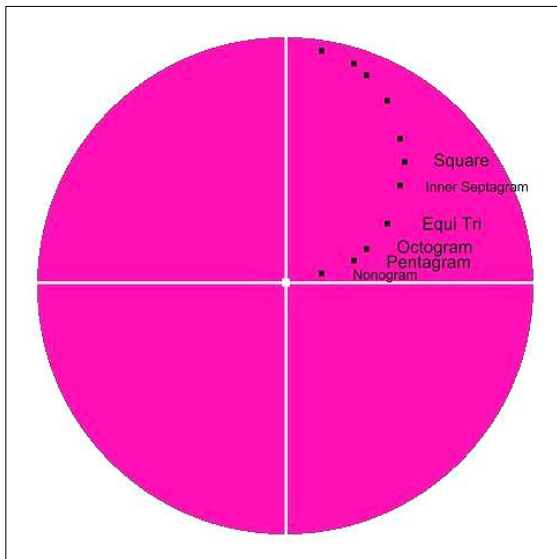

This early work on the Loci of the right angles in the right angled triangles gives a promising hint of the existence of a “hidden” Circle that is hitherto unknown but which radiates the ‘Harmony of Plane Regular Shape’.

This Loci of the Plane Regular Shapes marks out an **inalienable relationship** that connects each of these shape with all other Plane Regular Shapes.

I commenced this project in order to search for that which seemed to be:

“The Harmony of Plane Regular Shape”.

This harmony is what I believe Plato’s student Archimedes meant when he said
“It is first in the senses.”

One **senses** that this harmony exists in these shapes. They are, after all, the shapes of the Universe. They are the shapes of Nature. And, for the believers, they are the shapes of Creation.

POSSIBLE HARMONICS OF LOCI OF RIGHT ANGLED TRIANGLES IN PLANE REGULAR SHAPES GIVEN A FIXED CIRCUMSCRIBING CIRCLE

Points marked B

“Where the shape’s side is a Tangent to its Inscribing Circle”.

“Where the radius of the Inscribing Circle meets the Tangent”.

“Where the Radius and the Tangent meet at Right Angles”.

CURRENT SCIENCE

Is this the origin of what is known to us today as “Thales Theorem”?

If “Thales Theorem” was known to them was the *Hidden Circle of Harmony* also known?

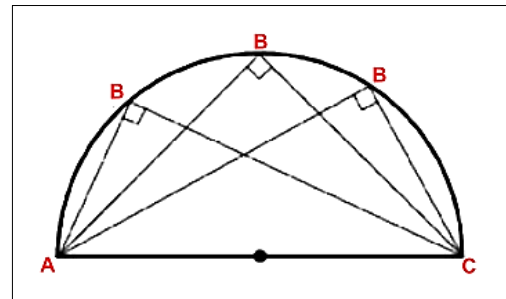

Is the *hidden circle* related to Thales Theorem?

Basically: An inscribed triangle in a semicircle with the diameter as its base is a right angle triangle.

So, nothing new there!

Refer to “THALES OF MILETUS c.626 – 548bc”

But, all plane regular shapes have inbuilt right angled triangles!

Through the very method of producing *plane regular shapes* by using **continuous tangents to an inscribing circle**, commencing at the circumference of a concentric circumscribing circle, we naturally introduce a right angled triangle into each and every such shape.

Tangents to Inscribing Circles are **always at right angles** to that circle’s Radius from its centre point to the Tangential Point on the Circumference.

THE ANCIENTS (bce)

- They had Thales Theorem.
- They had Stonehenge and the Pyramids.
- They had Plympton 322.
- They had Eratosthenes.
- They had Plato (c.428/427-348/347BC)
- They had all the makings.
- Then came Claudius Ptolemy
- Then came Kepler
- Then Newton, Maxwell, Faraday, Jenny and the rest.

MY PLANE SHAPE THEORY

This part of my theory was only revealed to me because I had an impulse to overlay several such shapes over each other in a transparent manner in order to track the path of the right angles.

Put simply, the result was an obvious arc of points that traced out a semi-circle; from the concentric centre of the forming circles to the common point of origin of the shapes at the top of the common circumscribing circle.

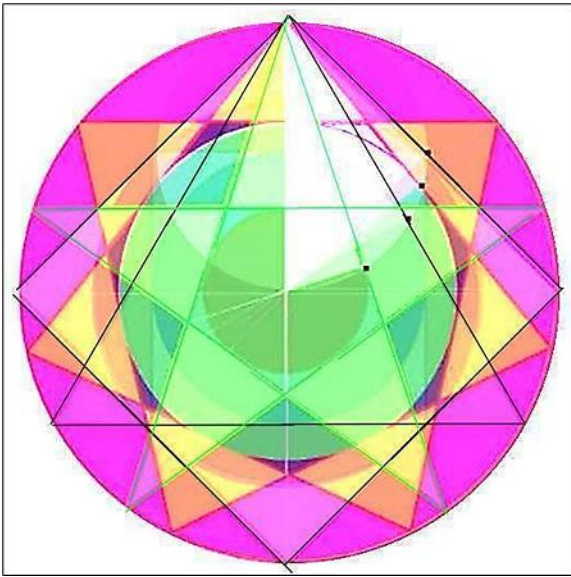

I had not applied this "hidden" circle to my experiments.

I was previously unaware of its existence.

It was this experiment that revealed the hidden Circle to me.

This Circle is not man made, nor planned nor designed.

It is a product or tool of Nature and Nature has revealed its existence.

But, it was only revealed to me after I had applied a "Fixed Circumscribing Circle" and thus a fixed size to my Plane Regular Shapes to enable comparative experimentation with them.

I utilised a fixed size Circumscribing Circle in order to compare each shape's features with the features of others. Even though physical size does not have any effect on a shape's ratio, one can do little real comparative physical research without imposing this physical size constraint.

CURRENT SCIENCE

"... point **A** is common to all"
THE GODDESS OF SOVEREIGNTY

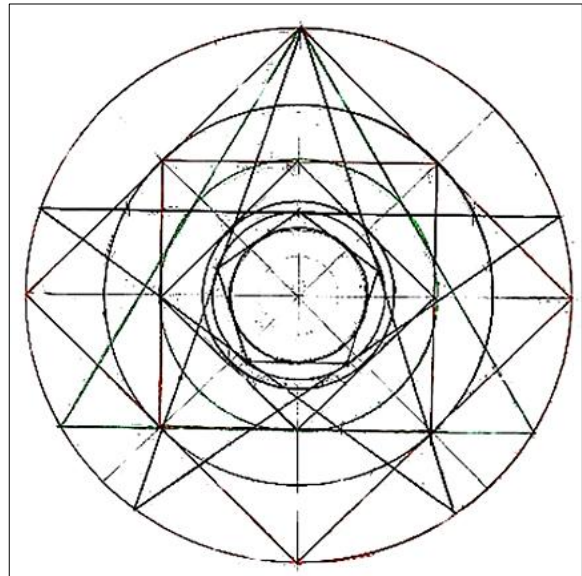

THE PHILOSOPHER'S STONE

Why is it that I never saw the similarity between my "Hidden Circle of Harmony" and "The Philosopher's Stone" before.

These illustrations were done over a decade apart and it was only when I placed them together in this document that the obvious similarities became apparent.

COMPONENTS OF A TOY BLOCK SET



ARE THE COMPONENTS OF THE PHILOSOPHER'S STONE & OF THE INNER CIRCLE OF HARMONY.

MY PLANE SHAPE THEORY

MY INNER CIRCLE OF HARMONY
Revealed to me by my analysis of inbuilt Right Angled Triangles in Plane Regular Shapes.

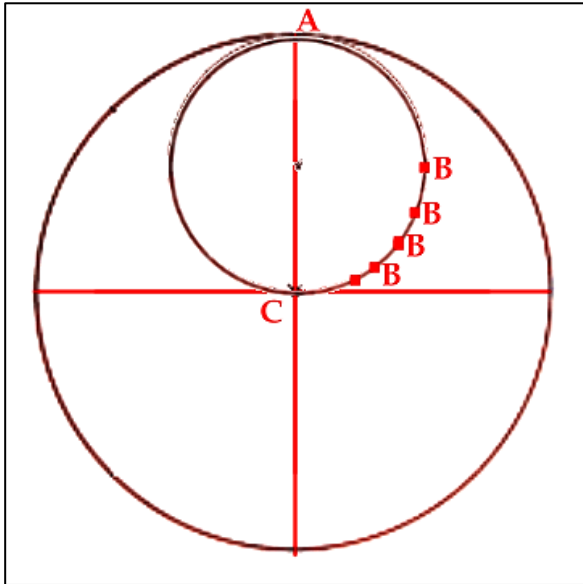

This **Circle of Inner Harmony**, or as I prefer, the **Ankh Circle** contains everything we see as necessary to produce all or any Plane Regular Shape.

It can control **the angle** of the shape's side from the apex angle (at point **A**) to the point where it is **a tangent** to the shape's inscribing circle (at whatever point **B** on this **Circle of Inner Harmony** is applicable).

It can control the selection of the Angle
and thus the Shape;

By intersecting the Inscribing Circle of the shape (at point **B**) it controls the length of the radius of the Inscribing Circle and therefore the shape's ratio and **the denomination of the shape** itself.

The Point **B** on the Ankh Circle that is on the same horizontal plane as the centre point of this Ankh Circle will produce **the Square**;

CURRENT SCIENCE

MY THEORY:

SHAPE RATIOS

IN THESE FEW EXAMPLES WE CAN SEE THE WAY THAT THE RATIOS APPEAR TO ORGANIZE THEMSELVES IN HARMONY.

| <u>SHAPE</u> | <u>RATIO</u> |
|----------------|-------------------|
| SQUARE: | 1.414213562373100 |
| INNER SEPT: | 1.618033988749890 |
| EQUI TRIANGLE: | 2.000000000000000 |
| OCTOGRAM: | 2.613125929752760 |
| PENTAGRAM: | 3.236067977499790 |
| NONOGRAM: | 5.656854249492380 |

THE SIZE OF THE **RATIOS** OF THE SHAPES APPEAR IN **ASCENDING** ORDER GOING FROM TOP TO BOTTOM.

From **A** to **C** via **B**.

CONVERSELY:

THE **APEX ANGLES** OF THE SHAPES ARE IN **DESCENDING** ORDER GOING FROM TOP TO BOTTOM.

From **A** to **C** via **B**

THE **RATIOS** ARE CALCULATED BY DIVIDING **A** to **C** BY THE RELEVANT **B** to **C**.

MY PLANE SHAPE THEORY

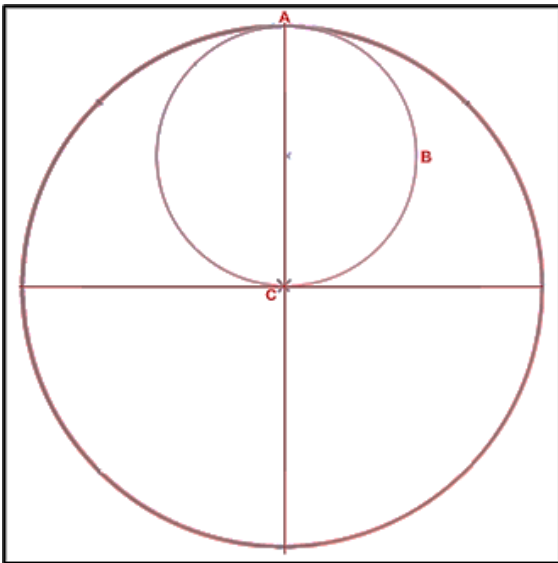

I consider this to be that for which I commenced this quest; that for which I had searched from the beginning of my quest.

'The Harmony of Plane Regular Shape'.

This image contains a previously *hidden* inner circle that may be used to encompass and illustrate the theory of Plane Regular Shape.

Every Plane Regular Shape has its source in the hemisphere denoted in true *Thales Theorem* style by **A B C** in the above image.

As I have never seen this circle before in the Literature I have taken the liberty to baptise it:

*"The Circle of Inner Harmony"
or alternatively "The Ankh Circle".*

CURRENT SCIENCE THE ANKH?

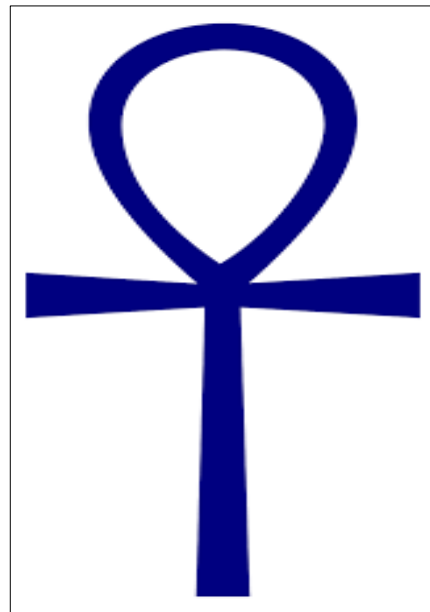

Was it the prototype for *THE EGYPTIAN ANKH*?
The Ankh is not dissimilar in shape to this *Hidden Circle* image.

It appears upon each and every Aten!

AND:

SCIAMVS 1 "Mathematical cuneiform tablets in Philadelphia" Tablet 11: N 4942

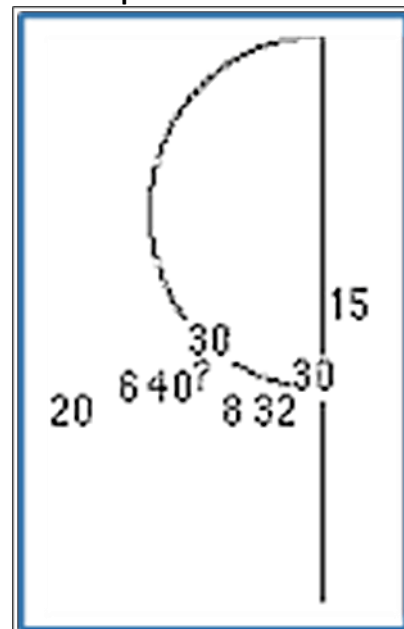

It is obviously a related geometric analysis of the "Ankh Circle" or of "The Inner Circle of Harmony"..

MY PLANE SHAPE THEORY

Every Plane Regular Shape has its own pair of Circles:

- A Circumscribing Circle

And its 'superpartner',

- An Inscribing Circle

General Relativity

CURRENT SCIENCE

SUPERSYMMETRY

"That's where supersymmetry, or SUSY, comes in. Supersymmetry predicts that each particle has what physicists call a "super partner" —

a more massive sub-atomic partner particle that acts like a twin of the particle we can observe.

Each observable particle would have its own kind of superpartner, pairing

bosons with "fermions,"
electrons with "selectrons,"
quarks with "squarks,"
photons with "photinos,"
and gluons with "gluinos."

A supersymmetric universe is one that would hold at least twice as many particles

Finding any particle that could be a dark matter candidate is nice because we could start to understand how it affects the galaxy and the evolution of the universe, but it also opens the door to whatever is on the other side, which we have no idea what is there.

Erin Blakemore

Correspondent

February 16, 2015

"The problem is that there are several things the Standard Model is unable to explain, for example the dark matter that makes up a large part of the universe. Many particle physicists are therefore working on the development of new, more comprehensive models."

MY PLANE SHAPE THEORYBLACK HOLE THEORIESSHAPE X SHAPE = SHAPE

THE MATRIX

THE RECIPROCAL MATRIX

"THE RECIPROCAL" OF THE RECIPROCAL MATRIX

THE REVERSABILITY OF RECIPROCAL RATIOS
CONCEPT.

CURRENT SCIENCEBLACK HOLE THERMODYNAMICS

"A central player in these developments is the black hole. **Black holes are a consequence of general relativity**, Albert Einstein's 1915 **geometric** theory of gravitation."

"In this theory, **gravitation arises from the curvature of spacetime**, which makes objects move as if they were pulled by a force. **Conversely, the curvature is caused by the presence of matter and energy.**"

"According to Einstein's equations, **a sufficiently dense concentration of matter or energy** will curve spacetime so extremely that **it rends, forming a black hole.**"

"The laws of relativity forbid anything that went into a black hole from coming out again, at least within the classical (**nonquantum**) description of the physics. "

"The point of no return, called the **event horizon** of the black hole, is of crucial importance. In the simplest case, the horizon is a sphere, whose surface area is larger for more massive black holes."

"It is impossible to determine what is inside a black hole. No detailed information can emerge across the horizon and escape into the outside world. "

MY PLANE SHAPE THEORY

MY SPIRAL OF SQUARES:

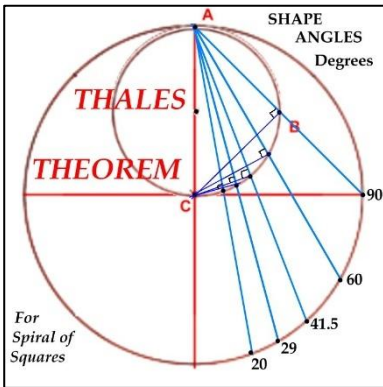

Squares inside Squares:

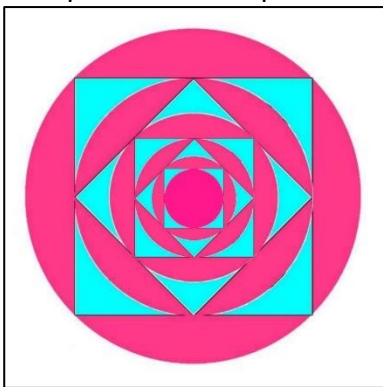

Reorientate the Squares:

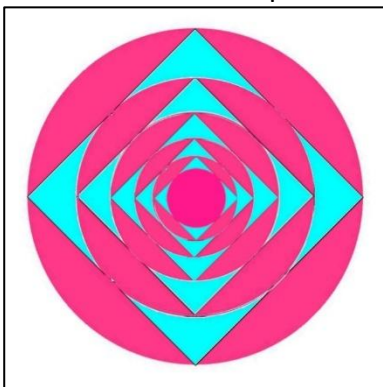

Apply the Inner Circle of Harmony

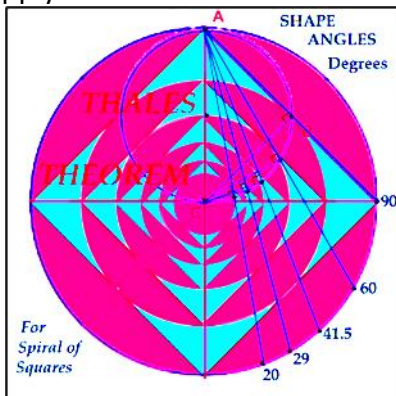

CURRENT SCIENCE

MY SHAPE THEORY

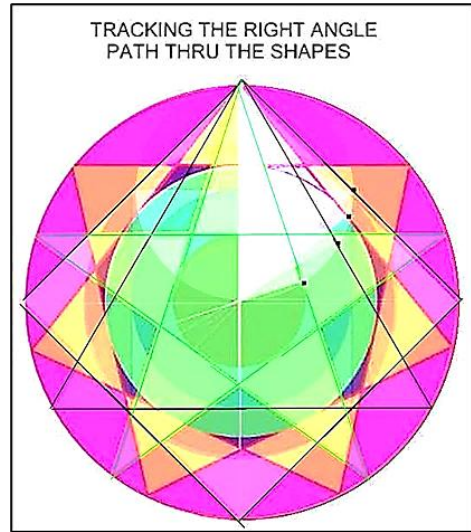

THALES THEOREM?

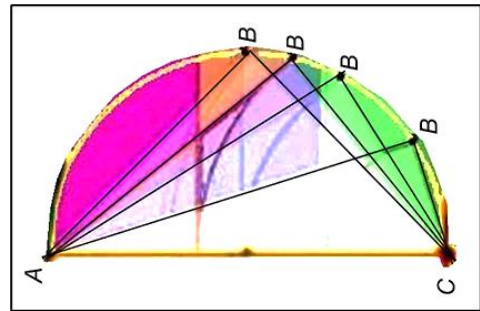

CERN ATLAS EXPERIMENTS

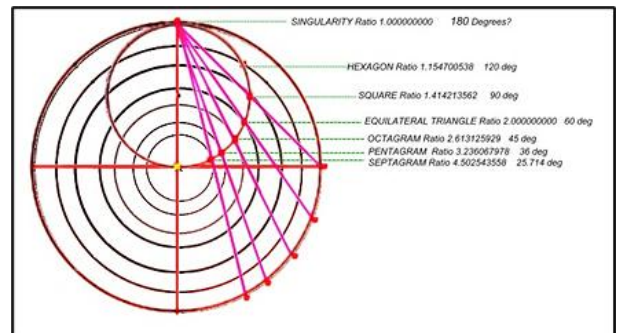
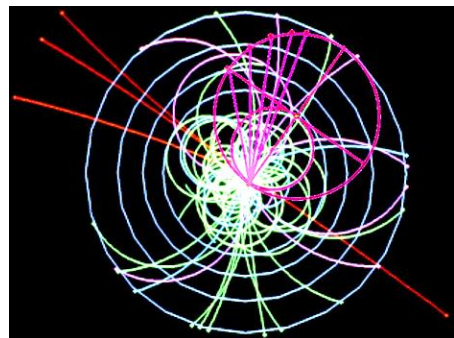

MY PLANE SHAPE THEORY

A SQUARE INSIDE A SQUARE ($\sqrt{2} \times \sqrt{2}$)
 INSIDE A SQUARE ($\times \sqrt{2}$)
 INSIDE A SQUARE ($\times \sqrt{2}$)
 INSIDE A SQUARE ($\times \sqrt{2}$)

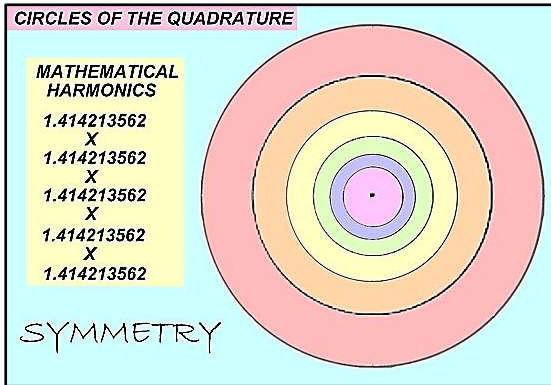

IRRELEVANCY OF 'AREA'

In this illustration each pair of adjacent circles with its own coloured 'dough in the doughnut' exist in the shape ratio to each other of $\sqrt{2}$ or 1.414213562.

In Shape Ratio terms all these coloured segments are **equal**.

In Physical Size terms they are clearly **unequal**.

Shape Ratios are therefore independent of the Physical Size of the shape.

A shape the size of a thimble will have the same ratio as the same shape the size of the Universe.

Do Plane Regular Shape Ratios apply equally both in the **Quantum** world and in the **General Theory of Relativity**?

CURRENT SCIENCE

The geometry contained upon:
A THAI HILLTRIBE SILVER PENDANT:



MY PLANE SHAPE THEORY

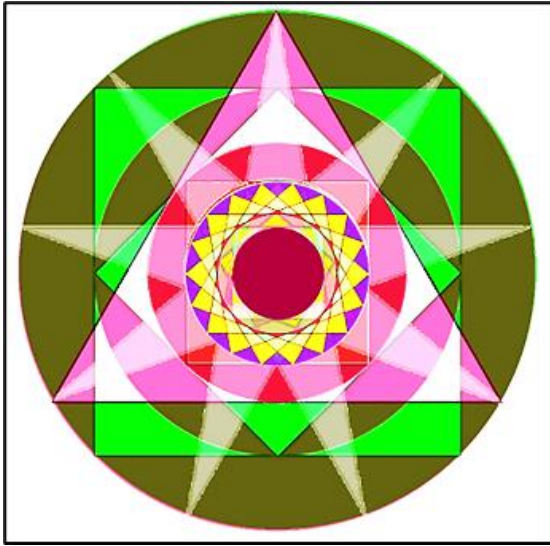

5.656854249492380 is the ratio for the Nonogram as is graphically shown above. Thus, by 'nesting' the shapes properly we are able to carry out graphical mathematics.

| | <u>Cumulative Product</u> | |
|-------------------|---------------------------|------------------------|
| | 1.0000000000000000 | Square |
| 1.414213562373100 | 1.414213562373100 | Square |
| 1.414213562373100 | 2.0000000000000000 | Square |
| 1.414213562373100 | 2.828427124746190 | 18 points – 80 degrees |
| 1.530733729460360 | 4.329568801169570 | Inner Nonogram |
| 1.306562964876380 | 5.656854249492380 | |

CURRENT SCIENCE

COMPONENTS OF A TOY BLOCK SET

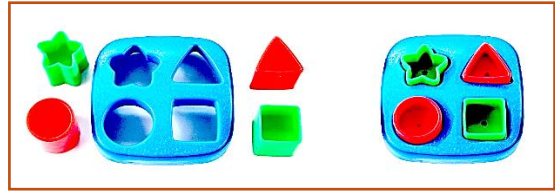

In the science of Cymatics (or if you wish 'Modal Phenomena') in order to know in advance what shape will be present when a certain frequency is applied, we really need to develop a Genome or List of shapes and their frequencies. Is this not the Science of Plato's **Two Harmonies** if we replace 'Shape' for his Astronomy?

We need to devise a Method to numerically categorize these Unique Ratios:

(Using their characteristics – **Degrees** at points; The **Shape**; **Shape Ratio**; Equivalent Audible **Frequency**)

These ratios or numbers are not randomly selected numbers such as those used for simulation theory but are real, applicable numerical ratios derived from the shapes and their concentric circles that actually can be used to produce as well as represent or simulate the shapes.

A number is obtained by dividing the shape's Outer Circle by its Inner Circle;

As circles can be defined simply by the length of their diameters (all other entities being common to both circles) then the ratio of one diameter to the other diameter provides the ratio of one circle to the other.

NB: No **AREA** calculations are required or used. –

No use of π (Pi) is required even though we are dealing with circles.

These Numbers epitomize the shapes both mathematically and graphically.

They control and represent the angles present in the points; in a reciprocal relationship except in the area of Dark Matter where they have crossed the Singularity and they exhibit an inverse orientation and become the reciprocal of the ratio.

*In the area of Dark Matter the Outer Circle then becomes the Inner and the Inner Circle then becomes the Outer. – **It is possible that the Shape has been turned inside out.***

MY THEORY

SHAPES IN PHASE

2 x 11 POINT POLYGRAMS IN PHASE

but its **ratio** is the same as that for one 11 point polygram

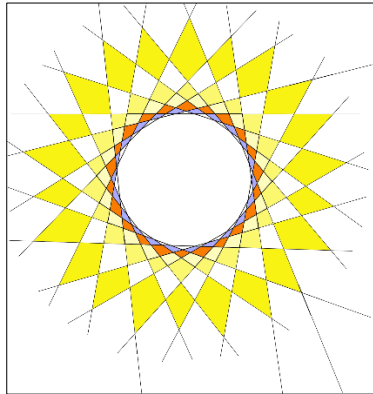

But this is not the primary or outer shape. There are two more shapes to see before the outer primary area is achieved;

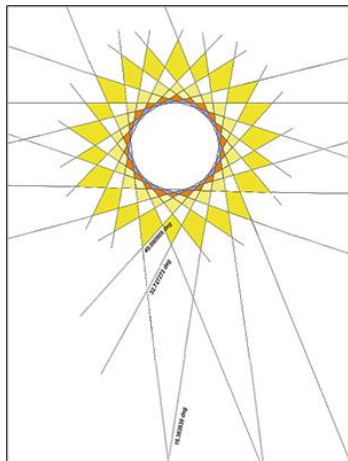

The Primary Shape is the area where the shape's sides or lines become parallel lines or which head off into space without crossing each other again and so are no longer able to form shapes.

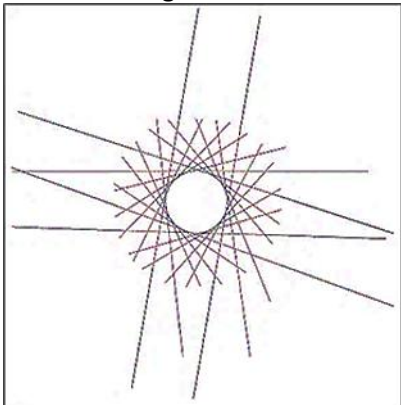

"... become parallel lines or which head off into space ..."

CURRENT SCIENCE

SUPERPOSITION

"General relativity is a classical theory, meaning that space-time takes on one, and only one, **shape** at every moment.

In contrast, matter is **quantum mechanical**, meaning it can have multiple possible states at once—a feature known as **superposition**.

Since space-time reacts to the matter in it, theorists expect that any matter particles in a superposition of occupying two different locations should force space-time into a superposition of two distortions.

That is, space-time and gravity should also follow quantum rules.

- o But physicists haven't yet worked out what those rules are."

BUT:-

Even in space Shape x Shape = Shape.

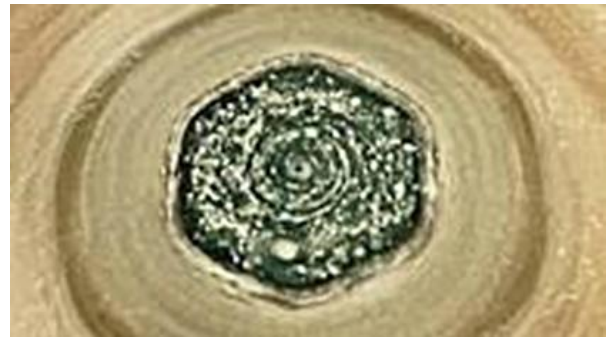

TWO EQUILATERAL TRIANGLES IN PHASE
Extension of the sides of this Hexagon to the next concentric circle out will reveal

Two Equilateral Triangles in Phase.

Shape x Shape = Shape

e.g. Equilateral Triangle x Hexagon = ?????
2.000000000 x 1.154700538 = 2.309401076

MY THEORYCURRENT SCIENCETHE DOUGH IN THE DOUGHNUT:

An important feature when dealing with multiple copies of a *shape-in-phase* is the 'Dough in the Doughnut' concept. All shapes-in-phase operate within the area of this doughnut, whether there are 3 copies, 5 copies, 10 copies etc.

A particular 'doughnut' has the same ratio regardless of the number of copies of a shape in phase that exist within its boundaries.

So, the ratio is virtually the doughnut whatever it contains.

Understanding the 'Dough in the Doughnut' concept:

The dough in the doughnut represents the limit of the sphere of influence or activity of the shape as it is formed by the continuous tangent. This tangent operates between the inner and outer limits to form the shape that is unique to the pair of circles in this particular ratio.

Many theories are concerned with *areas* of shapes but this 'Dough in the Doughnut' theory makes no reference at all to area; it is a sphere of influence defined by a ratio that has *no unit of measurement*. The constant π takes no part in this theory of shape.

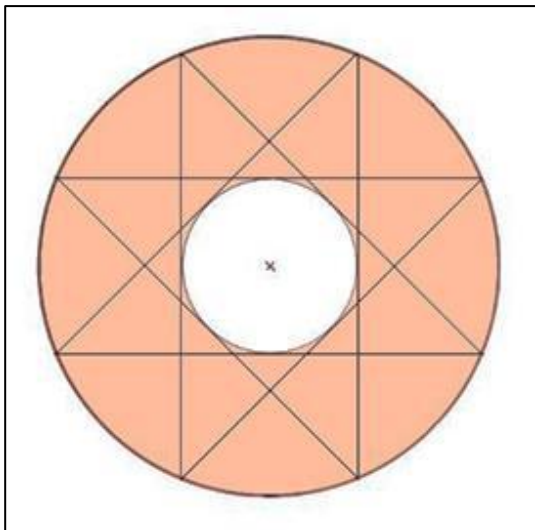

This image shows how all the 'construction' tangents that form the Octagram shape are formed and operate within the zone of the 'dough' only.

MY THEORY

Wider or narrower widths of 'dough' will form other shapes provided that the **continuous construction tangent** eventually returns again to the first or original **point of commencement**.

The centre of the Inscribing circle is vacant or empty.

Without an **inscribing circle** there would be no shape; so, **without a vacant or empty centre there can be no plane regular shape**.

—
"The Hole in the Doughnut".

Without a hole there is no doughnut.

PLANE REGULAR SHAPE AND THE HOLOGRAPHIC PRINCIPLE?

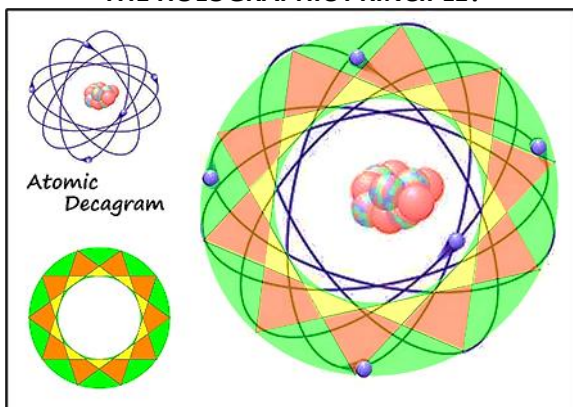

CURRENT SCIENCE

The **holographic principle** is a theory in physics, rooted in string theory and quantum gravity, that suggests **the description of a volume of space can be encoded on a lower-dimensional boundary, like a "hologram"**. It posits that **the maximum amount of information within any region of space is limited by its surface area, not its volume**, a concept derived from black hole thermodynamics. This principle offers a way to **reconcile quantum mechanics with the theory of relativity** and could potentially explain phenomena like dark matter and dark energy.

It took decades for physicists to accept that these **inconceivable objects, eventually dubbed black holes, might actually exist**.

J. Robert Oppenheimer and Hartland Snyder calculated in 1939 that if a perfectly spherical star gravitationally collapses to a point, its matter will become so dense that it will stretch space-time into a singularity.

But real stars bubble and churn, especially while imploding, so physicists wondered whether their nonspherical shapes would stop them from forming singularities.

Penrose eliminated the need for geometric perfection in 1965. His landmark proof relied on two assumptions.

- **First**, you need a "trapped surface" inside of which light can never escape. If you cover this surface in light bulbs and switch them on, their light rays will fall inward faster than they can travel outward. Crucially, this shell of light will shrink regardless of whether it started out as a perfect sphere, a dimpled golf ball, or something more misshapen.
- **Second**, space-time should always curve in such a way that light rays bend toward each other but never diverge. In short, gravity should be attractive, which is the case so long as energy is never negative.

With these two stipulations, Penrose proved the mortality of at least one of the trapped light rays.

Its otherwise eternal journey through space and time must terminate in a singularity, a point where the space-time fabric ceases to exist, where there is no future for the light ray to travel into.

MY THEORY

I believe that the whole world (*myself included*) for eons has looked at two-dimensional plane regular shape and simply yawned considering the topic to be simply kindergarten stuff (*myself included*). This is so far from the truth that looking back now after years of research I cannot believe that I too yawned at the prospect of plane regular shape being anything more than just plane regular shape; just building blocks for infants to play with. Plane Regular Shapes are the building blocks of the Universe exhibiting the *Mathematics of the Universe*.

And what are these infants' building blocks?

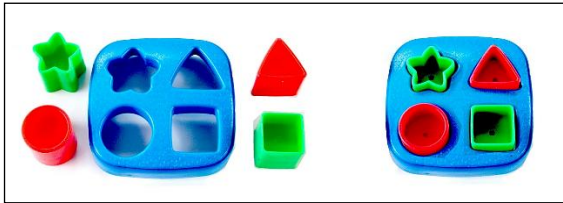

They are the components of the Philosopher's Stone: The Square; the Circle; the Pentagon; and the Equilateral Triangle.

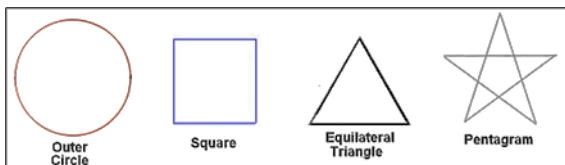

Plato's Geometric Number?

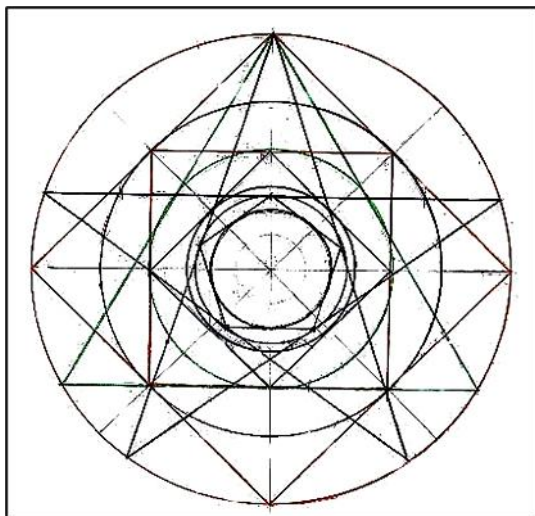

The Philosopher's Stone

CURRENT SCIENCE

ILLUSTRATION: Roger Penrose, *Physical Review Letters*, American Physical Society

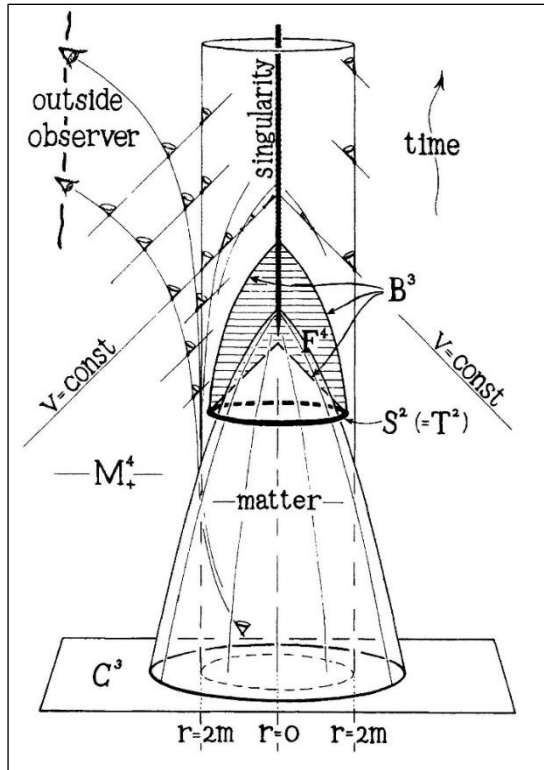

Caption: A hand-drawn figure in Penrose's 1965 paper proving the singularity theorem shows the collapse of space-time to form a singularity. The paper has been called "the most important paper in general relativity" since Einstein's.

MY THEORY

MY PLANE REGULAR SHAPE ANALYSIS OF GLEDHILL'S 25 Hz sine wave IMAGE

The following two images illustrate how every circle in Gledhill's Cymatic Result is part of the subharmonic structure of the whole 12 point polygram. The intermediate circles are the inner and outer circles for each of the "**Construction Harmonic**" shapes.

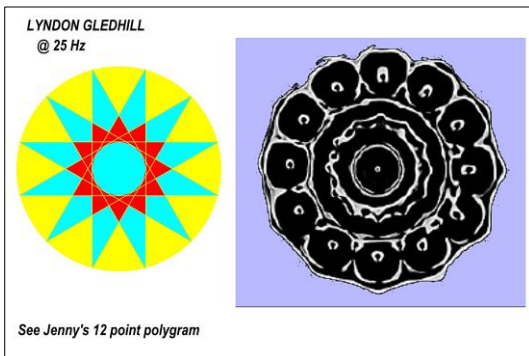

The rough shapes of these circles even suggest the orientation of these subharmonic shapes.

My drawing clearly shows from inside to outside: the square, equilateral triangle and the 12 points.

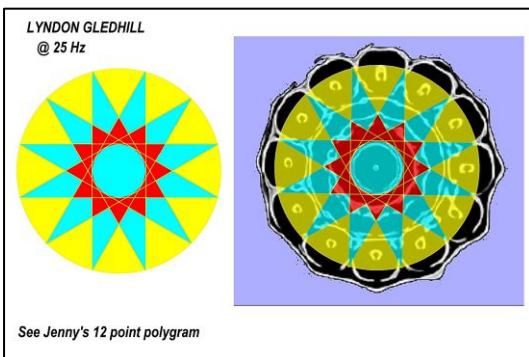

CURRENT SCIENCE

"Particles as Waves"

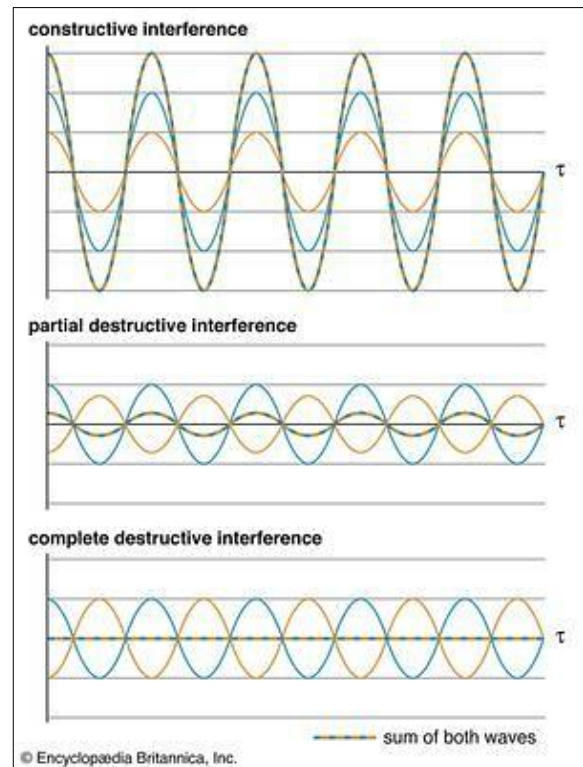

principle of superposition, in wave motion, the principle that when two or more waves overlap in space, the resulting disturbance is equal to the algebraic sum of the individual disturbances. This principle holds for many different kinds of waves, such as

- waves in water,
- sound waves,
- and electromagnetic waves.

Because of the principle of superposition, the old saying that no two things can occupy the same space at the same time does not apply to waves.

Indeed, an infinite number of waves can occupy the same space at the same time. Furthermore, they do this without affecting one another, so that each wave retains its own character independent of how many other waves are present at the same point and time.

MY THEORY

We realise:

That Shape co-relates with music and square roots and Lord knows with what else; perhaps even with the scale of elements, or the atomic masses;

That a theory of shape harmonics gives us a yardstick to measure the Universe without using a Unit of Measurement.

We no longer need to include time in the equation. You may say that time is built into the equation through the measurement of "frequency" as cps or cycles per **second**.

Measurement of shape itself is, however, void of any unit of measurement. It is purely and simply a Ratio of two variables.

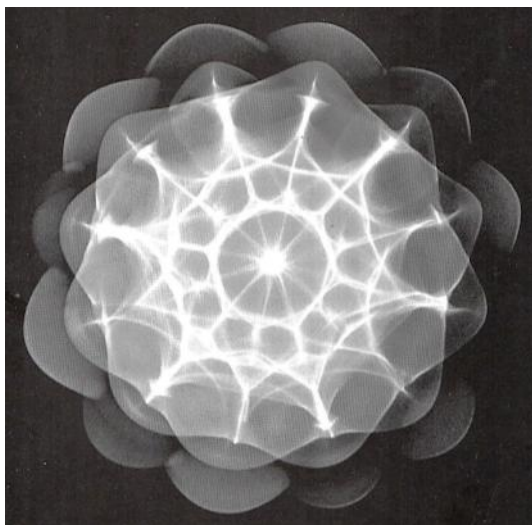
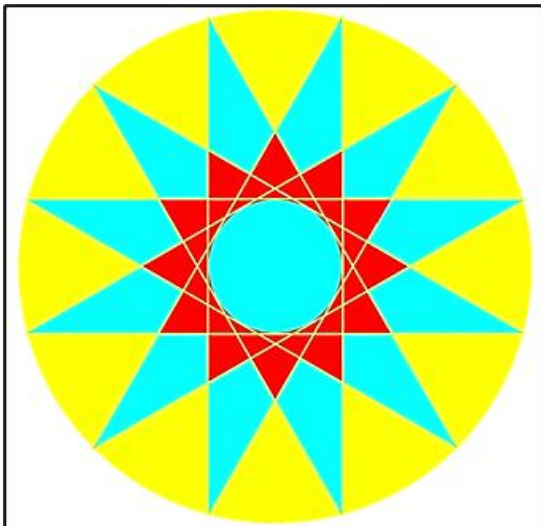

JENNY'S CLASSICAL 12 POINT IMAGE

CURRENT SCIENCE

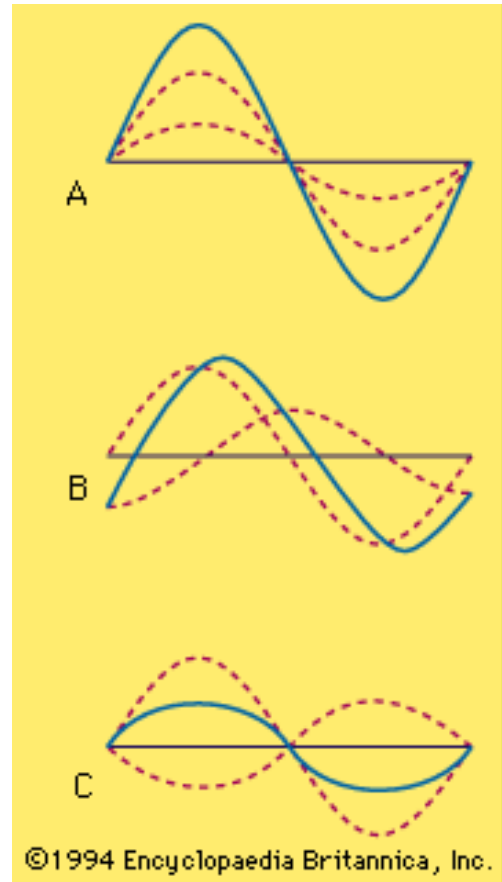

If two of the components are of the **same frequency and phase** (i.e., they vibrate at the same rate and are maximum at the same time), the wave amplitudes are reinforced, producing constructive interference.

But if the two waves are **out of phase** by $\frac{1}{2}$ period (i.e., one is minimum when the other is maximum), the result is destructive interference, producing complete annulment if they are of equal amplitude.

The solid line in Figures A, B, and C represents the resultant of two waves (dotted lines) of slightly different amplitude but of the same wavelength.

The two component waves are in phase in Figure A but out of phase by $\frac{1}{4}$ period and $\frac{1}{2}$ period in B and C.

MY THEORY

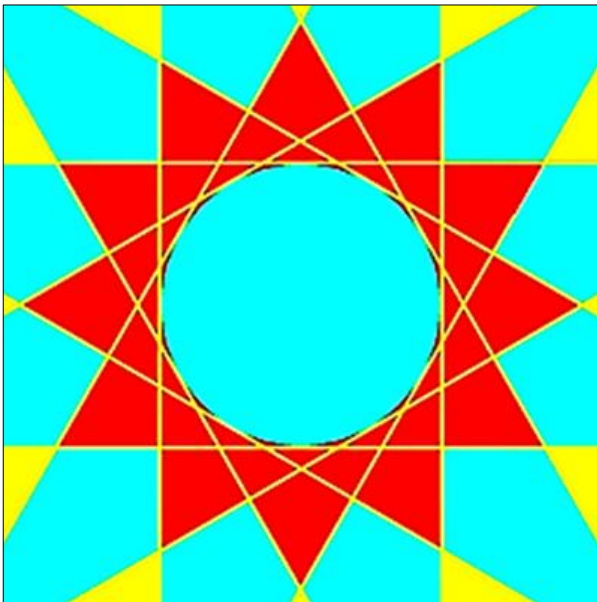
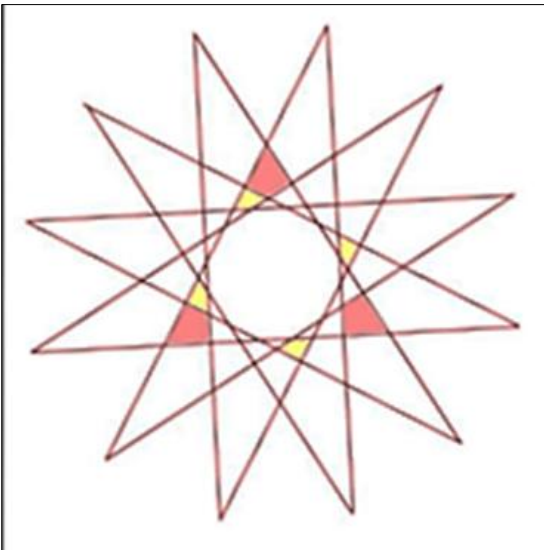
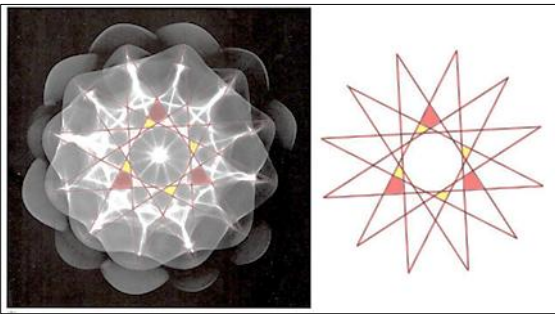

- 1 TWELVE POINT POLY**GON**= 12
- 2 HEXAGONS IN PHASE2 X 6 = 12
- 3 SQUARES IN PHASE 3 X 4 = 12
- 4 EQUILATERAL TRIANGLES IN PHASE ... = 12
- 1 TWELVE POINT POLY**GRAM**=12

CURRENT SCIENCE

SUPERPOSITION

Superposition plays a key role in many of the wave properties of sound. One such example is interference.

There are two types of interference effects.

In ***constructive interference*** the crests of two waves coincide, and the waves are said to be in phase with each other. Their superposition results in a reinforcement of the disturbance; ***the amplitude of the resulting combined wave is the sum of the individual amplitudes.***

Conversely, in ***destructive interference*** the crest of one wave coincides with the valley of a second wave, and they are said to be out of phase. The amplitude of the combined wave equals the difference between the amplitudes of the individual waves.

In the ***special case where those individual amplitudes are equal***, the destructive interference is complete, and the net disturbance to the medium is zero.

MY PLANE SHAPE THEORY

A MICRO / MACRO VIEW:
WHERE PHYSICAL SIZE IS IRRELEVANT.

Any harmonic existence within the mechanism we know as *infinity* requires a rethinking of our approach to this notion.

- Without *infinity*
there would be NO Shape.
- Without *infinity*
there would be NO Music.
- Without *infinity*
there would be NO Square Roots.
- Without *infinity*
there would be NO Trigonometry.
- Without *infinity*
there would be NO Sorting Constants.

This theory requires that we embrace Infinity
And not avoid it.

(PHYSICAL SIZE IS IRRELEVANT IN SHAPE THEORY)

CURRENT SCIENCE

A MACRO VIEW:

NASA'S JUNO MISSION

JUPITER'S OCTAGON POLE



Red areas show where magnetic field lines
emerge from the planet

Blue areas show where they return

The imagery will help the team understand the forces at work in the animation – a north pole dominated by a central cyclone surrounded by **eight circumpolar cyclones** with diameters ranging from 2,500 to 2,900 miles (4,000 to 4,600 kilometers).

(PHYSICAL SIZE IS IRRELEVANT IN SHAPE THEORY)

Images captured by NASA's Juno probe show Jupiter's poles in a **bluish hue**, revealing large cyclones and a dynamic, chaotic atmosphere. These details have surprised scientists for their difference with the equatorial regions of the planet.

Juno has also recorded brilliant auroras in the South Pole, offering valuable data on the interactions between Jupiter's magnetic field and the solar wind. These discoveries are expanding our understanding of the atmosphere and internal structure of the gas giant.

MY THEORY**SHAPE TO MUSIC CORRELATION**

Because a differential exists between the Shape Ratio and the Music Note Frequency then, in Cymatics, there should be a slight difference between the Music Note Frequency and the Frequency at which the applicable Shape result is found.

| Root Five | a | a/2 |
|--|--------------------------------|-------------------|
| $\sqrt{5} + 5$ | 7.236067977499790 | 3.618033988749890 |
| $\sqrt{5} + 4$ | 6.236067977499790 | 3.118033988749890 |
| $\sqrt{5} + 3$ | 5.236067977499790 | 2.618033988749890 |
| $\sqrt{5} + 2$ | 4.236067977499790 | 2.118033988749890 |
| $\sqrt{5} + 1$ | 3.236067977499790 | 1.618033988749890 |
| $(\sqrt{5} + 3) / 2$ or Φ^2 | 2.618033988749890 | 1.309016994374950 |
| $(\sqrt{5} + 1) / \sqrt{2}$ | 2.288245611270740 | 1.144122805635370 |
| $\sqrt{2}^2$ | 2.000000000000000 | 1.000000000000000 |
| $(\sqrt{5} + 2) / 2$ | 57 deg 41 pts | 2.118033988749890 |
| $\frac{((\sqrt{5} + 1) / \sqrt{2}) / 2 \times 4}{\text{or } ((\sqrt{5} + 1) / \sqrt{2}) \times 2}$ | 4.576491222541470 Septagram | 2.288245611 |

The use of Pianos to produce frequencies to associate with cymatics experiments ignores the fact that pianos have "sounding Boards" in them which can mix the frequencies.

CURRENT SCIENCE

NASA - Astronomy ·

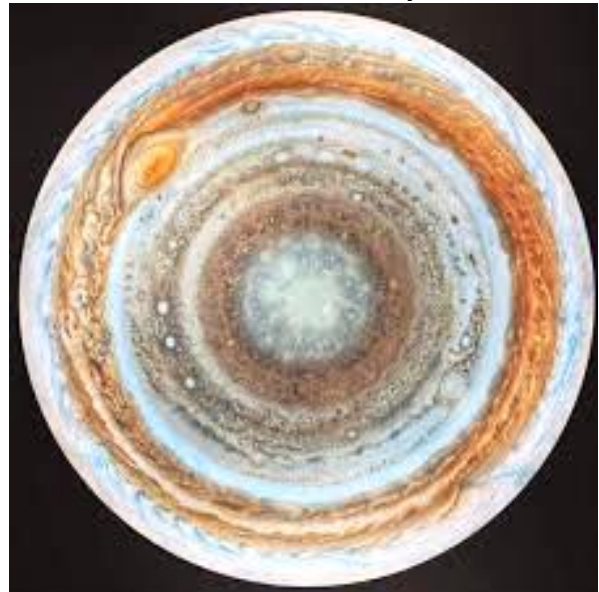

JUPITER'S POLE

MANY CONCENTRIC CIRCLES

"Jupiter, **seen from below**, unveils a hypnotic stormscape of swirling clouds and raging tempests. This rare Cassini view captures the gas giant's dynamic beauty, with its iconic Great Red Spot resting at the edge. A planet of unrelenting motion, Jupiter stands as a colossal masterpiece of the cosmos."

AND WITH MANY CONCENTRIC CIRCLES.

Jupiter's Pentagon Turns Hexagon

NASA Science (.gov)

<https://science.nasa.gov> › [photojournal](#) › [jupiters-penta...](#)

12 Dec 2019 — In this annotated infrared **image**, six cyclones form a **hexagonal** pattern around a central cyclone at **Jupiter's south pole**, as detected by the Jovian Infrared Auroral Mapper (JIRAM) instrument aboard NASA's Juno mission during its 23rd science pass of the planet. The JIRAM instrument measures heat radiated from the planet at an **infrared wavelength** of around 5 microns.

More information about Juno is online at <http://www.nasa.gov/juno> and <http://missionjuno.swri.edu>.

MY THEORY

PAUL ADRIEN DIRAC

Dirac believed that the language of quantum mechanics was not English. Neither was it German or Danish. The only language capable of explaining quantum mechanics was mathematics. Word explanations of quantum behavior were bound to fail, or at best be poor approximations.

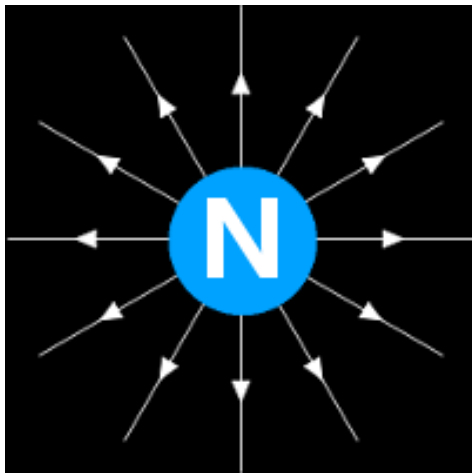

A solitary north magnetic pole with magnetic field lines.

His equations gave him a reason – they said electric charge is quantized because one or more magnetic monopoles exist somewhere in the universe.

However, never in history had a magnetic pole been seen in isolation. North poles were always accompanied by south poles and vice versa.

Furthermore, magnetic monopoles would violate Gauss's law for magnetism, $\nabla \cdot \mathbf{B} = 0$, one of Maxwell's equations.

Magnetic monopoles have still not been seen, but the universe is a big place for the solitary monopole needed to explain charge quantization to hide!
Research continues.

CURRENT SCIENCE

JUPITER'S HEXAGON SOUTH POLE

In this annotated infrared **image**, six cyclones form a **hexagonal** pattern around a central cyclone at **Jupiter's south pole**:

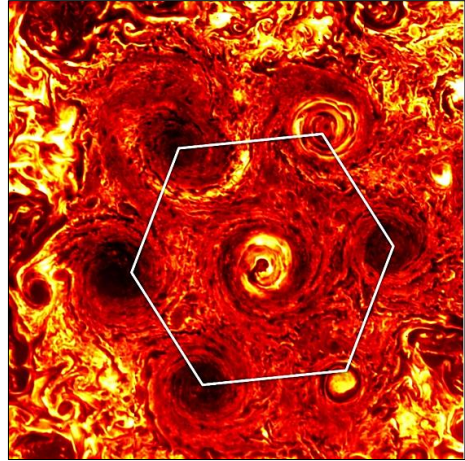

NASA's Jet Propulsion Laboratory manages the Juno mission for the principal investigator, Scott Bolton, of Southwest Research Institute in San Antonio. Juno is part of NASA's New Frontiers Program, which is managed at NASA's Marshall Space Flight Center in Huntsville, Alabama, for NASA's Science Mission Directorate.

"Before Juno, we could only guess what Jupiter's poles would look like," said Alberto Adriani, Juno co-investigator from the Institute for Space Astrophysics and Planetology, Rome. "Now, with Juno flying over the poles at a close distance it permits the collection of infrared imagery on Jupiter's polar weather patterns and its massive cyclones **in unprecedented spatial resolution.**"

JUPITER'S OCTAGON NORTH POLE

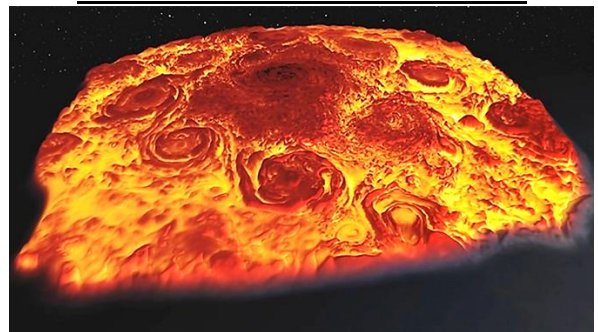

The imagery will help the team understand the forces at work in the animation – a north pole dominated by a central cyclone surrounded by eight circumpolar cyclones with diameters ranging from 2,500 to 2,900 miles (4,000 to 4,600 kilometers).

MY THEORY

PAUL ADRIEN DIRAC

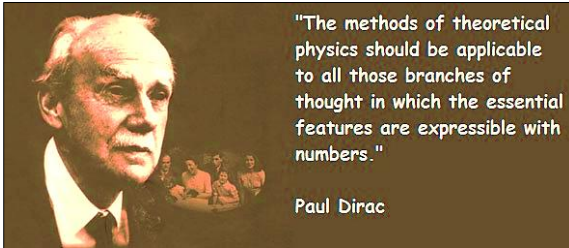

"God is a mathematician of a very high order, and He used very advanced mathematics in constructing the universe."

Paul Adrien Maurice Dirac (8 August 1902 – 20 October 1984) was a British theoretical physicist and a founder of the field of quantum physics.

*It seems to be one of the fundamental features of nature that fundamental physical laws are described in terms of **a mathematical theory of great beauty and power**, needing quite a high standard of mathematics for one to understand it. You may wonder: Why is nature constructed along these lines? One can only answer that our present knowledge seems to show that nature is so constructed. We simply have to accept it.*

*One could perhaps describe the situation by saying that **God is a mathematician of a very high order, and He used very advanced mathematics in constructing the universe**. Our feeble attempts at mathematics enable us to understand a bit of the universe, and as we proceed to develop higher and higher mathematics we can hope to understand the universe better.*

CURRENT SCIENCE

JUPITER'S OCTAGON NORTH POLE

JUNO'S IMAGE

NASA's Juno Mission Provides Infrared Tour of Jupiter's North Pole

This infrared 3-D image of Jupiter's north pole was derived from data collected by the Jovian Infrared Auroral Mapper (JIRAM) instrument aboard NASA's Juno spacecraft.

NASA/JPL-Caltech/SwRI/ASI/INAF/JIRAM

Infrared cameras are used to sense the temperature of Jupiter's atmosphere and provide insight into how the powerful cyclones at Jupiter's poles work. In the animation, the yellow areas are warmer (or deeper into Jupiter's atmosphere) and the dark areas are colder (or higher up in Jupiter's atmosphere). In this picture the highest "brightness temperature" is around 260K (about -13°C) and the lowest around 190K (about -83°C).

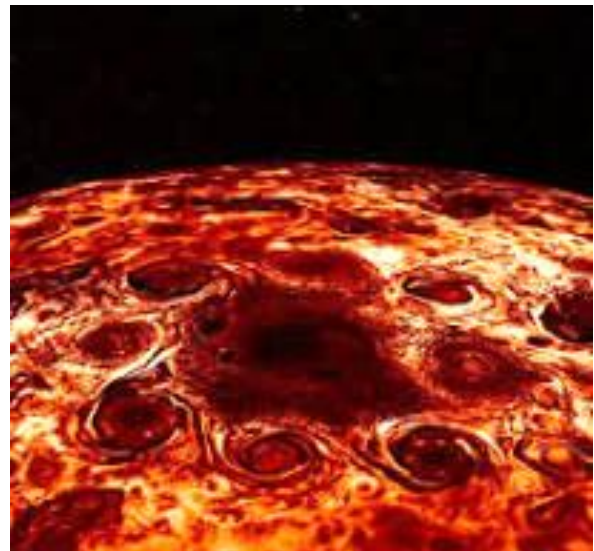

MY THEORY**The theory of Plane Regular Shape**

Partially outlined above.

PAUL ADRIEN DIRAC

"Just by studying mathematics we can hope to make a guess at the kind of mathematics that will come into the physics of the future. A good many people are working on the mathematical basis of quantum theory, trying to understand the theory better and to make it more powerful and more beautiful. "

"If someone can hit on the right lines along which to make this development, it may lead to a future advance in which people will first discover the equations and then, after examining them, gradually learn how to apply them."

The methods of theoretical physics should be applicable to all those branches of thought in which the essential features are expressible with numbers.

Paul Dirac

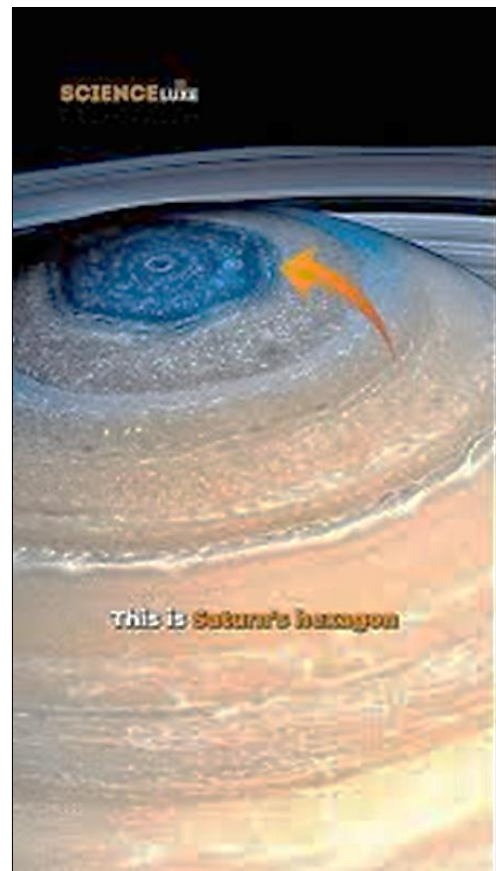
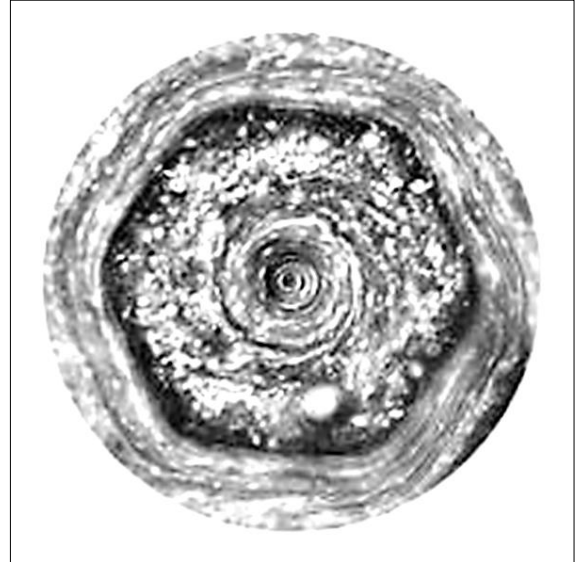
CURRENT SCIENCE**SATURNS HEXAGON NORTH POLE****CASSINI'S IMAGE**

MORE CONCENTRIC CIRCLES

MY THEORY



CURRENT SCIENCE

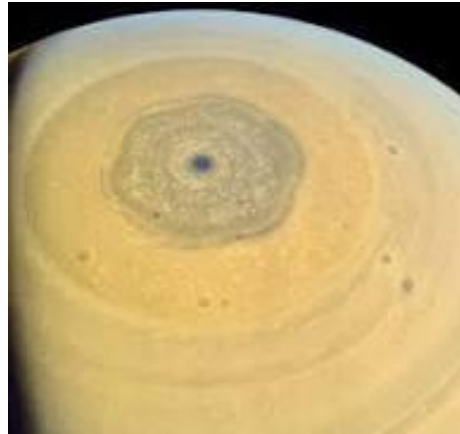

A SYSTEM OF CONCENTRIC CIRCLES



There's a giant hexagon-shaped storm at Saturn's north pole and it's larger than Earth.

SIZE IS IRRELEVANT IN SHAPE THEORY



TWO EQUILATERAL TRIANGLES IN PHASE

Extension of the sides of this **Hexagon** to the next concentric circle out will reveal *Two Equilateral Triangles in Phase*.
"SHAPE X SHAPE = SHAPE"

MY THEORY**MY GOLDEN MEAN DERIVATION**

Taken from the observed idiosyncrasies of ϕ & Φ

$$\Phi = 1 + \phi$$

$$\text{And } \phi^2 = \Phi$$

$$\text{And } \phi^2 = 1 + \phi$$

My object was to Iterate $v(1+n)$

Where **n** is the value of any starting number or the previous result of the application of this iterative equation.

| $v(1+n)$ |
|--------------------------|
| 0.284079044000000 |
| 1.133172115788240 |
| 1.460538296583910 |
| 1.568610307432640 |
| 1.602688462375840 |
| 1.613284991058880 |
| 1.616565801648320 |
| 1.617580230359010 |
| 1.617893763619540 |
| 1.617990656221330 |
| 1.618020598206750 |
| 1.618029850839210 |
| 1.618032710064670 |
| 1.618033593614380 |
| 1.618033866646300 |
| 1.618033951017810 |
| 1.618033977090040 |
| 1.618033985146800 |
| 1.618033987636480 |
| 1.618033988405830 |
| 1.618033988643570 |
| 1.618033988717040 |
| 1.618033988739740 |
| 1.618033988746760 |
| 1.618033988748930 |
| 1.618033988749600 |
| 1.618033988749800 |
| 1.618033988749870 |
| 1.618033988749890 |
| 1.618033988749890 |
| 1.618033988749890 |
| 1.618033988749890 |
| 1.618033988749890 |
| 1.618033988749890 |

The iteration of this simple equation will reduce (or increase) **any number** to an approximation of the Golden Mean,

CURRENT SCIENCE**RAMANUJAN**

$$\left(\sqrt{\frac{5 + \sqrt{5}}{2}} - \frac{1 + \sqrt{5}}{2} \right)$$

$$= 0.2840790440000000$$

ME

| Root Five | a | a/2 |
|---|--------------------------------|-------------------|
| $\sqrt{5} + 5$ | 7.236067977499790 | 3.618033988749890 |
| $\sqrt{5} + 4$ | 6.236067977499790 | 3.118033988749890 |
| $\sqrt{5} + 3$ | 5.236067977499790 | 2.618033988749890 |
| $\sqrt{5} + 2$ | 4.236067977499790 | 2.118033988749890 |
| $\sqrt{5} + 1$ | 3.236067977499790 | 1.618033988749890 |
| $(\sqrt{5} + 3) / 2$ or Φ^2 | 2.618033988749890 | 1.309016994374950 |
| $(\sqrt{5} + 1) / \sqrt{2}$ | 2.288245611270740 | 1.144122805635370 |
| $\sqrt{2}^2$ | 2.000000000000000 | 1.000000000000000 |
| $(\sqrt{5} + 2) / 2$ | 57 deg 41 pts | 2.118033988749890 |
| $\{((\sqrt{5} + 1) / \sqrt{2}) / 2\} \times 4$ or $\{(\sqrt{5} + 1) / \sqrt{2}\} \times 2$ | 4.576491222541470 Septagram | 2.288245611 |

PLATO

PEMPAD 'PLUS ONE' ?

PACIOLI

Taken from the observed idiosyncrasies of ϕ & Φ

$$\Phi = 1 + \phi$$

and

$$\phi^2 = \Phi$$

and

$$\phi^2 = 1 + \phi$$

MY THEORY

Because a differential exists between the Shape Ratio and the Music Note Frequency then, in Cymatics, there should be a slight difference between the Music Note Frequency and the Frequency at which the applicable Shape result is found.

There is always the "Sorting Constant"

0.000000000000030

Found in my *Shape to Music* Correlations.

The Universe is out of complete balance by just enough to keep its systems operating, responding to other systems and advancing at each point to the next phases.

A mathematically balanced Universe would stagnate, seize up & stop.

CURRENT SCIENCE**CYMATICS**

CHLADNI'S Cymatics results

JENNY'S Cymatics results

FARADAY'S Cymatics results

JOHN STUART REID and his Cymascope.

TELFER'S Cymatics results

LAUTERWASSER'S Cymatics results

LINDON GLEDHILL'S Cymatics results

AND EVEN MY OWN Cymatics results

MY THEORY

PLATO'S PEMPAD 'plus the one'

| Root Five | a |
|---|--------------------------------|
| $\sqrt{5} + 5$ | 7.236067977499790 |
| $\sqrt{5} + 4$ | 6.236067977499790 |
| $\sqrt{5} + 3$ | 5.236067977499790 |
| $\sqrt{5} + 2$ | 4.236067977499790 |
| $\sqrt{5} + 1$ | 3.236067977499790 |
| $(\sqrt{5} + 3) / 2$ or Φ^2 | 2.618033988749890 |
| $(\sqrt{5} + 1) / \sqrt{2}$ | 2.288245611270740 |
| $\sqrt{2}^2$ | 2.000000000000000 |
| $(\sqrt{5} + 2) / 2$ | 57 deg 41 pts |
| $\{[(\sqrt{5} + 1) / \sqrt{2}] / 2\} \times 4$ or $\{[(\sqrt{5} + 1) / \sqrt{2}] \times 2$ | 4.576491222541470 Septagram |

| a | a/2 |
|--------------------------------|-------------------|
| 7.236067977499790 | 3.618033988749890 |
| 6.236067977499790 | 3.118033988749890 |
| 5.236067977499790 | 2.618033988749890 |
| 4.236067977499790 | 2.118033988749890 |
| 3.236067977499790 | 1.618033988749890 |
| 2.618033988749890 | 1.309016994374950 |
| 2.288245611270740 | 1.144122805635370 |
| 2.000000000000000 | 1.000000000000000 |
| 57 deg 41 pts | 2.118033988749890 |
| 4.576491222541470 Septagram | 2.288245611 |

RAMANUJAN'S CONTINUOUS EQUATIONS

CURRENT SCIENCE

| Root Five | a | a/2 |
|---|--------------------------------|-------------------|
| $\sqrt{5} + 5$ | 7.236067977499790 | 3.618033988749890 |
| $\sqrt{5} + 4$ | 6.236067977499790 | 3.118033988749890 |
| $\sqrt{5} + 3$ | 5.236067977499790 | 2.618033988749890 |
| $\sqrt{5} + 2$ | 4.236067977499790 | 2.118033988749890 |
| $\sqrt{5} + 1$ | 3.236067977499790 | 1.618033988749890 |
| $(\sqrt{5} + 3) / 2$ or Φ^2 | 2.618033988749890 | 1.309016994374950 |
| $(\sqrt{5} + 1) / \sqrt{2}$ | 2.288245611270740 | 1.144122805635370 |
| $\sqrt{2}^2$ | 2.000000000000000 | 1.000000000000000 |
| $(\sqrt{5} + 2) / 2$ | 57 deg 41 pts | 2.118033988749890 |
| $\{[(\sqrt{5} + 1) / \sqrt{2}] / 2\} \times 4$ or $\{[(\sqrt{5} + 1) / \sqrt{2}] \times 2$ | 4.576491222541470 Septagram | 2.288245611 |

RAMANUJAN

His ratios were mostly Plane Regular Shape Ratios but he dealt with them differently.

$$\left(\sqrt{\frac{5 + \sqrt{5}}{2}} - \frac{1 + \sqrt{5}}{2} \right)$$

IF the $\sqrt{}$ symbol was meant to cover the whole equation:

$$= \sqrt{(3.618033989 - 1.618033989)}$$

$$= \sqrt{2}$$

= $\sqrt{\text{Equilateral Triangle}}$
= A Square
(Square x Square = Equilateral Triangle)
(Graphically)

BUT if $\sqrt{}$ is only meant to cover the first part of the equation:

$$= \sqrt{(3.618033989)} - 1.618033989$$

$$= 1.902113033 - 1.618033989$$

$$= 0.284079011$$

The Reciprocal of which is **3.520147428**

Shape Ratio
56pts 31.03448deg 3.702459172
= Stonehenge Stage 1.
= Aubrey Holes to Bluestone Circle

MY THEORY

$$\sqrt{1+n} \quad \text{if } n = \varphi$$

CURRENT SCIENCE

| 1.618033989000000 | 2.618033989559250 |
|--------------------------|--------------------------|
| 1.618033988827180 | 1.902113032803060 |
| 1.618033988773780 | 1.703558931414780 |
| 1.618033988757280 | 1.644250264228280 |
| 1.618033988752180 | 1.626115083328450 |
| 1.618033988750600 | 1.620529260250630 |
| 1.618033988750110 | 1.618804886405590 |
| 1.618033988749960 | 1.618272191692610 |
| 1.618033988749920 | 1.618107595833050 |
| 1.618033988749900 | 1.618056734429620 |
| 1.618033988749900 | 1.618041017536210 |
| 1.618033988749900 | 1.618036160762860 |
| 1.618033988749890 | 1.618034659938670 |
| 1.618033988749890 | 1.618034196158620 |
| 1.618033988749890 | 1.618034052842710 |
| 1.618033988749890 | 1.618034008555670 |
| 1.618033988749890 | 1.618033994870210 |
| 1.618033988749890 | 1.618033990641180 |
| 1.618033988749890 | 1.618033989334330 |
| 1.618033988749890 | 1.618033988930500 |
| 1.618033988749890 | 1.618033988805700 |
| 1.618033988749890 | 1.618033988767140 |
| 1.618033988749890 | 1.618033988755220 |
| 1.618033988749890 | 1.618033988751540 |
| 1.618033988749890 | 1.618033988750400 |
| 1.618033988749890 | 1.618033988750050 |
| 1.618033988749890 | 1.618033988749940 |
| 1.618033988749890 | 1.618033988749910 |

MY THEORYDIATOMS**How can a single celled Critter:**

- Know Inner Circles and their use with Outer Circles in the formation of Plane Regular Shape?
- Distinguish between Primary and Secondary Shapes?
- Know about the frequencies used to form such shapes?
- Know how to produce and/or access these frequencies?
- Know to produce the Outer denticles to indicate the presence of further harmonics?

If they could not produce their own shapes were they then produced by some external force or factor?

MUSIC TO SHAPE CORRELATION?

CURRENT SCIENCE**Mic-UK: Oamaru Diatoms**

Microscopy-UK566 × 500

Melosira clavigera Grunow in Van
Heurck. Papakaio, Oamaru. Mounted by
Dr. Charles L. Odam, November 1945.

Ex. Collection of F. C. Wise

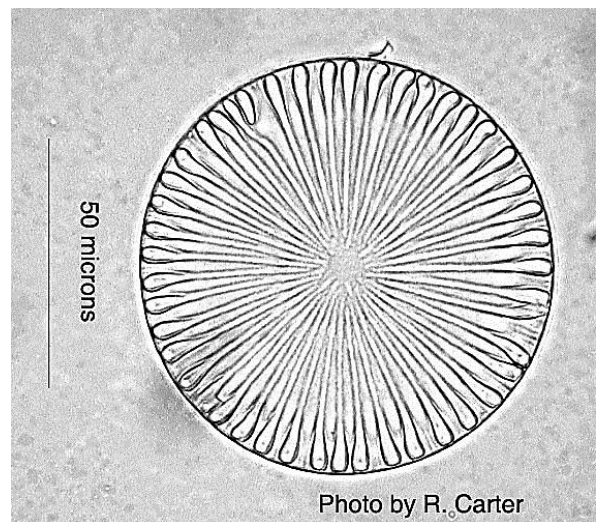

46 points or 2 x 23 points in phase (prime).

Note the Circle formed by the short sides of the “petals”. It is subtle but still present.

MY THEORY

THE THEORY OF
PLANE REGULAR SHAPE

THE DESIGN AND SHAPE OF NATURE.

CURRENT SCIENCE

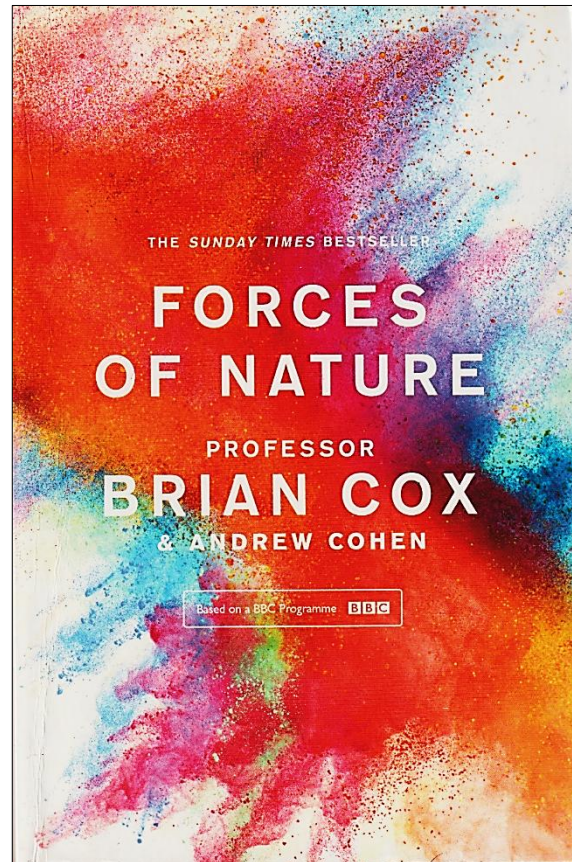

This isn't intended to be a complete course on particle physics, much as I'd like to deliver that; rather, it is a chapter about shapes and patterns in Nature and what they reveal about the way in which the Universe works.

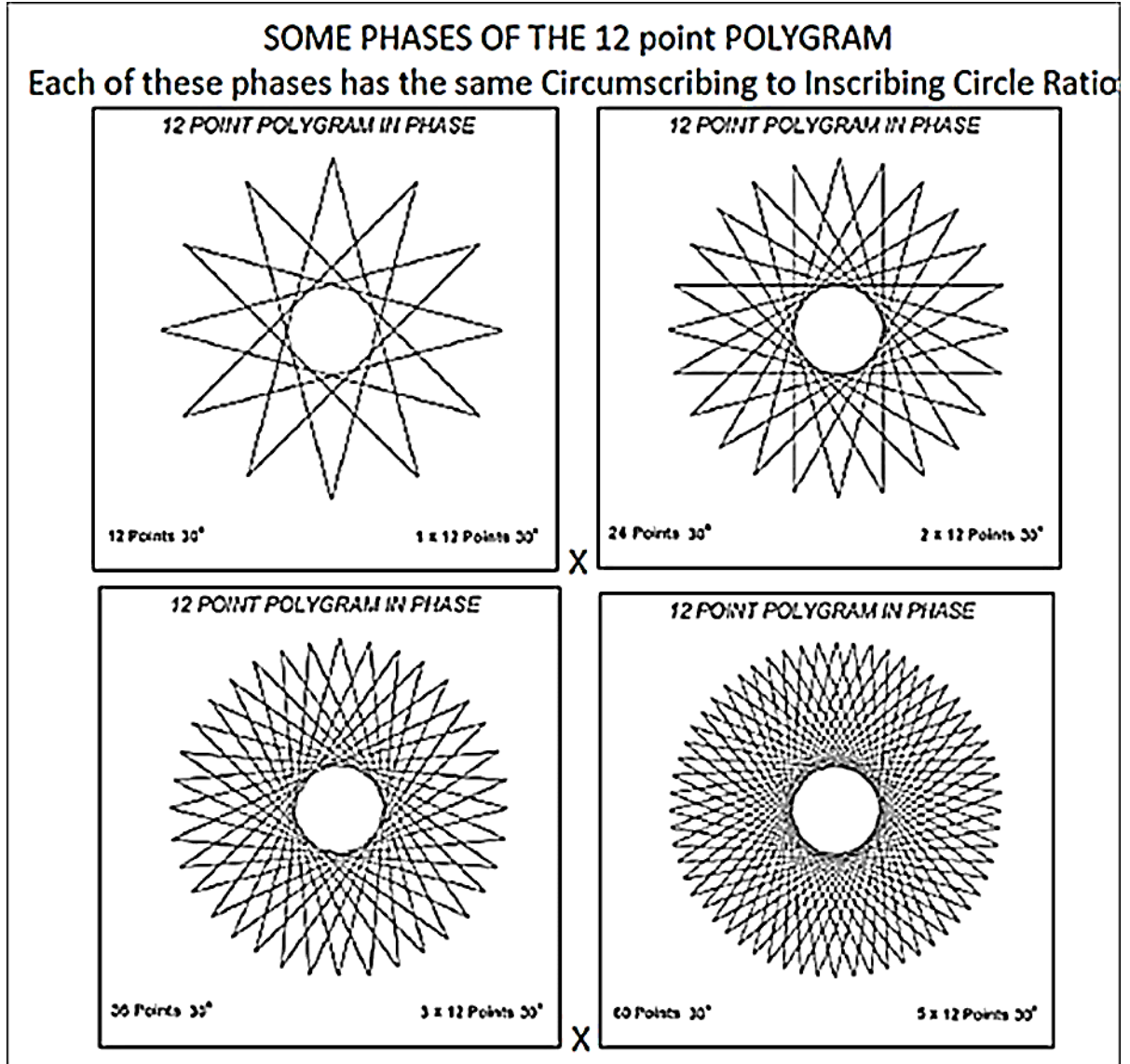
SHAPES IN PHASE

23 point polygram – PRIME

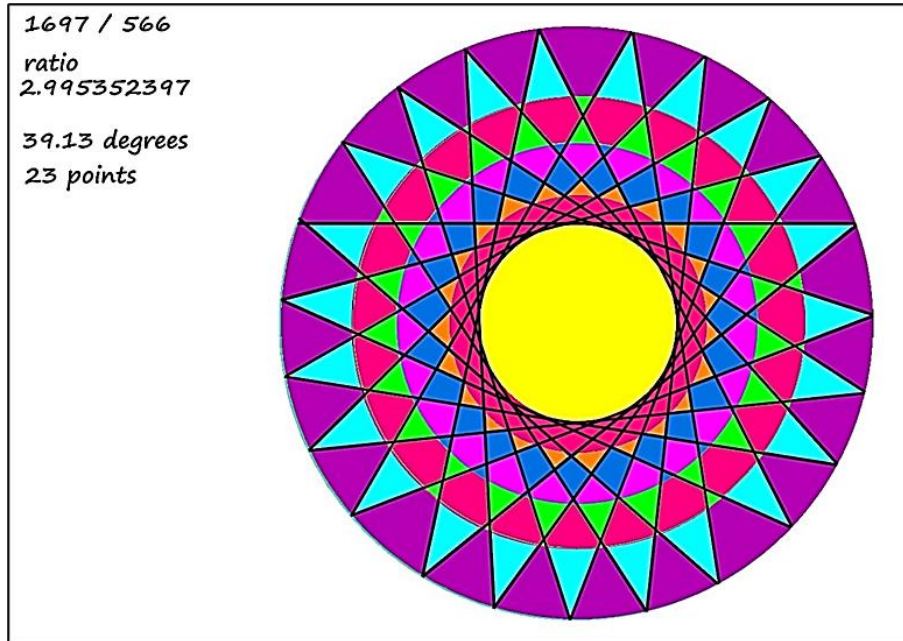

MY MUSIC TO SHAPE TO DIATOM CORRELATION:

| Note | Music | DEGREES | SHAPE | Shape Ratios | Shape | Shape / Music | DIATOM & SHAPE Points | DIATOM Genus | DIATOM Species |
|----------------|-------------|--------------|--------|-------------------------------------|-------------------------|---------------------------|-----------------------------|----------------------------|--------------------------|
| | FREQ / 100 | | | Ratios including refined results | Harmonic Multipliers | Differential Harmonics | | | |
| D ₃ | 2.936647679 | 39.130434780 | 23 pts | 2.995352392 | 1.059016994 | 1.019990383 | 23 / 46 23 / 46 | Arachnoidiscus Melosira | Ehrenbergii Clavigera |

2 x 23 points in phase.

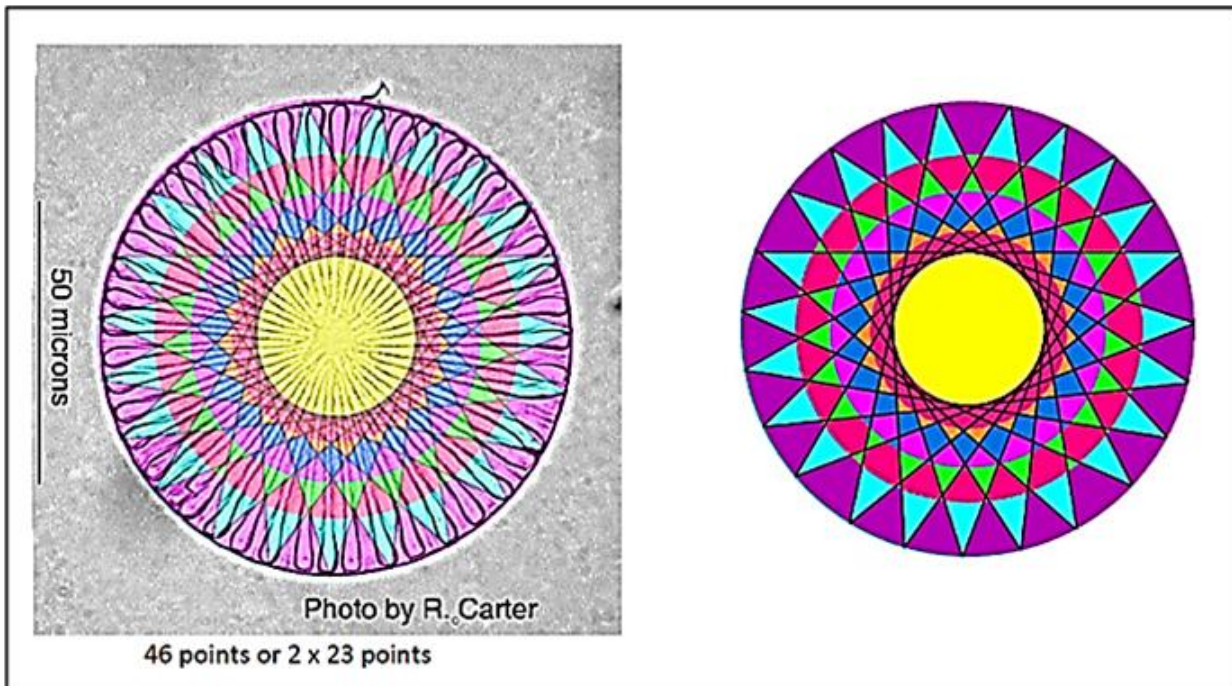

WITH THE SHAPE SUPERIMPOSED OVER THE DIATOM IMAGE

Comparing the Shape's features with those of the Diatom.

(My Stonehenge Theorem)

"In any set of three or more Concentric Circles if a shape ratio exists between all adjacent pairs of these circles then shape ratios exist between any pairs of these circles+. (Refer the Matrix)

This is not Trigonometry as we know it (but Ptolemy Claudius in 150ad went terribly close to discovering it with his system of chords); it's not Calculus as we know it; it's not Algebra as we know it; it's not Geometry as we know it; it's not the Fibonacci Sequence as we know it; it's not Number Theory as we know it but it contains features of all areas of mathematics.

THE MAGIC THAT IS THE MATRIX
(If the Shape Theorem is universally applicable)
MATRIX OF KNOWN CORRECT RATIOS

| MULTIPLICATION MATRIX | | | pentagram | 13pts 41.53846154deg | Equilateral Triangle | Square | pentagon |
|-----------------------|----------------------|-------------------|--------------------|----------------------|----------------------|-------------------|-------------------|
| | | | 3.236067977499790 | 2.828427124746190 | 2.000000000000000 | 1.414213562373100 | 1.236067977499790 |
| 36 | pentagram | 3.236067977499790 | 10.472135954999600 | 9.152982445082950 | 6.472135954999580 | 4.576491222541490 | 4.000000000000000 |
| 41 | 13pts 41.53846154deg | 2.828427124746190 | 9.152982445082950 | 8.000000000000000 | 5.656854249492380 | 4.000000000000010 | 3.496128195590570 |
| 60 | Equilateral Triangle | 2.000000000000000 | 6.472135954999580 | 5.656854249492380 | 4.000000000000000 | 2.828427124746200 | 2.472135954999580 |
| 90 | Square | 1.414213562373100 | 4.576491222541470 | 4.000000000000000 | 2.828427124746190 | 2.000000000000010 | 1.748064097795280 |
| 108 | pentagon | 1.236067977499790 | 4.000000000000000 | 3.496128195590570 | 2.472135954999580 | 1.748064097795290 | 1.527864045000420 |

IF A SHAPE MULTIPLIED BY A SHAPE EQUALS A THIRD SHAPE then the Matrix results should all be Shapes:

| | | |
|----------------|----------|-------------------|
| 18degrees | 20pts | 6.472135954999560 |
| 20degrees | nonogram | 5.656854249492380 |
| 29.032258deg | 31pts | 4.000000000000000 |
| 33degrees | 120pts | 3.496128197000000 |
| 41.53846154deg | 13pts | 2.828427124746190 |
| 48degrees | 30pts | 2.472135954999580 |
| 69.23076923deg | 13pts | 1.666666666666660 |
| 81.818181deg | 11pts | 1.527864046000000 |

These results were taken from my "Degree – Shape – Ratio" suggested Genome of Shape

Observe Plane Regular Shapes to ascertain their common features:

- Polygons and Polygrams; the circle, the square and the equilateral triangle.
- Note that they all have some common characteristics:
 - Naturally, they are all two-dimensional.
 - Given, they are all of course equi-angular and equi-lateral.
 - They can all have **Circumscribing AND Inscribing Circles** delineating their outer and inner boundaries. - (The outer edges of the dough in the doughnut).
 - Each Shape has a unique **pair** of concentric circles present in a **unique Ratio** for that shape.
 - These ratios co-exist in a **set** that displays incredible harmonics – the harmonies of Nature.

Devise a Method to numerically categorize these Unique Ratios: (using these common characteristics):

- These ratios or numbers are not randomly selected numbers as used for simulation theory but are real, applicable numerical ratios derived from the shapes that actually can be used to produce and represent the shapes.
 - A number is obtained by dividing the shape's Outer Circle by its Inner Circle; As circles can be defined simply by the length of their diameters (all other entities being common to both circles) then the ratio of one diameter to the other diameter provides the ratio of one circle to the other. NB: No **AREA** calculations are required or used. - (*more like Euclid's Line Ratios*)
 - These Numbers epitomize the shapes both mathematically and graphically.
 - They control and represent the angles present in the points; in a reciprocal relationship except in the area of Dark Matter where they have crossed the Singularity and they exhibit an inverse orientation until they can become the reciprocal of the reciprocal. *In the area of Dark Matter the Outer Circle then becomes the Inner and the Inner Circle then becomes the Outer.*
 - They can be the basis of a system of purely **graphical mathematics**.
 - They constitute a system that is the epitome of *Visual Mathematics*.

Basic Assumptions:

- *Something from Nothing:-*
 - **Lines** have no width;
 - **Points** have no dimensions;
 - **Tangents** *without thickness* pass through only one **dimensionless point** on the *widthless and depthless* circumference of a circle.
- This System of Ratios forms **Harmonic Sequences** which lead to the discovery of **Shape Theorems**.
 - A Shape Ratio multiplied or divided by another Shape Ratio will produce yet another Shape Ratio which I refer to as a **Harmonic Multiplier**. These Harmonic Multipliers are also shapes.
 - Shape Ratios are only produced from Shape Ratios. (*Music Frequencies from Music Frequencies etc.*)
 - In a set of three or more concentric circles if a shape exists between each adjacent pair of circles then a shape will exist between any pair of these circles. -- (*My Stonehenge Theorem*) (7 Concentric Circles).
- The nature of these **Shape Theorems** prompts us to apply **matrices** to reveal more shape ratios
 - These new ratios need to be then tested graphically.
 - Eventually there should exist a 'genome' of Plane Regular Shape. – *Within the visible spectrum*.
 - These Ratios should enable the graphic production and testing of the Shapes by Computer.
 - Once a fairly substantial 'genome' has been established then the pattern (or patterns) of **harmonic multipliers** should be revealed. This 'genome' should, in reality, be infinite.

Approach the Theory as if you were in the period before Trigonometry; as if you were an Ancient:

- There is evidence in Stone and in Clay Tablets that shape harmonics were known 5000 years ago.
 - *Stonehenge; Durrington Walls; The Sanctuary; The Pyramids;*
 - *Clay Tablets*
 - *BM15285; The Quadrature;*
 - *Ashmolean 1924.457 with the 07:12 multiplication table used later by Eratosthenes; ("Old Babylonian **Marad** School tablet, type III multiplication table x 7:12")*
 - *Hippias and Ptolemy; Plato; Eratosthenes;*
 - **Antedeluvians:** *Anu, Adam, Noah, **Enmeduranki and the Divine Kibdu Tablet;***

Harmonic Sequences within the Theory:

- Not just one but Several Harmonic Sequences are revealed by this theory.
 - **Brian Greene** of Columbia University seeks patterns. He also seeks harmonics "*like Music*".
 - From an 'integer' ordered list of Polygons we can produce a sequence of Complimentary **Primary** shapes (mostly Polygrams) ad infinitum. -- cf. **Cantor's Continuum Hypothesis**.
 - We can discern **Secondary** Shapes that stem from these Primary Shapes, possibly also from sequences of harmonics;
 - Such harmonics I have classified as either **construction harmonics** or as **mathematical harmonics**, invisible without further graphical analysis.
 - We can devise harmonic lists of '**Index Numbers**' for the shapes which illustrate more harmonies and enable the extension of the list of Complimentary Shapes.
 - We can then discover a repetitive **code** within Index Numbers existing within lists of these **polygon – to – primary polygram** shape conversions:

| | | | | | |
|--------------|--------------|--------------|---------------|--------------|--------------|
| 2, 1, 2 0.5; | 2, 1, 2 0.5; | 2, 1, 2 0.5; | 2, 1, 2, 0.5; | 2, 1, 2 0.5; | 2, 1, 2 0.5; |
|--------------|--------------|--------------|---------------|--------------|--------------|

2 - 1 - 2 - 0.5

- The Size of Shape Ratios exists in some **reciprocal order** to that of the angles contained in the shapes except in the area of 'Dark Matter' (Inner circle divided by the Outer circle) where the sizes of angles and ratios are in a similar order.
- There are NO calculations using π in this system. There are no **area** calculations required nor do we measure the lengths of the circumferences. So, π becomes a red herring in this theory. This is a new approach to dealing with circles; - circle mathematics without π .
- Numerically ordered lists of certain shape ratios bear complete correlation with **Music Notes** after allowing for a **harmonic differential** which contains a microscopic '**sorting**' constant.
- Numerically ordered lists of certain shape ratios bear complete correlation with **Square Roots of Integers** after allowing for a differential which contains a microscopic '**sorting**' constant.
- Numerically ordered lists of certain shape ratios should bear complete correlation with applicable lists of **Ptolemy's Chords** after allowing for a refinement of Ptolemy's numeration. (His work was, by his own admission, '*sufficient for the senses*').
- The ratio $\sqrt{2}$ and the ratio 2 ($\sqrt{2} \times \sqrt{2}$) along with multiples exist in all three entities: Music; Shape; Square Roots. They are the basic underlying harmonic influences. (I submit that they could be the source of the **anthypharesis** theories of the late David Herbert Fowler of the Maths Institute at Warwick University in the U.K. and of the late Wilbur Knorr)
- The number 2 is a shape ratio (for the Equilateral Triangle) and in this theory does not refer to *doubling* or *halving*. When a shape ratio is being multiplied or divided by 2 it is being multiplied or divided by the equilateral triangle; by a shape in the true nature of the shape theorems.

The Incommensurable Nature of Shape Ratios:

- With the exception of 2 and its integer multiples all plane regular shape ratios are incommensurable numbers which give an insight into the workings of **Infinity** in our Universe. (But even 2 is $\sqrt{2} \times \sqrt{2}$.)
 - Although Shape, Music and Square Root Ratios are incommensurable they co-exist with other ratios *harmonically* in a totally commensurable manner within their own system.
 - They also co-exist *harmonically* in a totally commensurable manner with systems of other entities such as Music and Square Roots and Ptolemy's Chords (*and possibly therefore with Trigonometry subject to issues of accuracy?*).
 - This harmonic existence within the mechanism we know as *infinity* requires a rethinking of our approach to this notion.
 - Without *infinity* there would be NO Shape.
 - Without *infinity* there would be NO Music.
 - Without *infinity* there would be NO Square Roots.
 - Without *infinity* there would be NO Trigonometry.
 - Without *infinity* there would be NO Sorting Constants.
 - This theory requires that we embrace Infinity not avoid it. **Mandelbrot** avoided Infinity specifically when he was developing his fractals theory. He set boundaries between $+/- 2$.
 - We can embrace Infinity by accepting and recognizing the unique and special work played by incommensurable numbers in Music, Shape and Square Roots and by realizing that they can be commensurable in their own way with each other in their own environment.

Affinities between Plane Regular Shape, Music, Frequency, Vibrations:

- The mathematical correlation discovered between Music and Shape through the use of these Shape Ratios infers that it is certainly possible, if not simple, to develop a mathematical system to account for Cymatic (*Modal Phenomena*) **and other vibrational experiments** that produce shape and/or other **stray frequencies** in their results. *Could Shape Frequencies be interfering with their results?*
- The accuracy of existing **theses** in the areas of *Vibrations, Resonances and Frequencies, & Modal Phenomena* would be enhanced by the use of this system of mathematics, ratios and harmonics.
 - There would no longer be a need to *assume* reasons for inexplicable results.
 - Similarities that have been found in the past need no longer remain “unexplained”.
 - **Classifications of Crystals** may be enhanced.
 - **Resonance Theory** – The frequency of a shape can be important. Do Shapes influence resonance?
 - **Steven Lehar’s** unfinished work on harmonics in the Brain could be enhanced. He could proceed past the fourth chapter.
 - **Lord Raleigh’s** work on earthquakes and vibrations.
 - **Fourier** Fast Transforms – FFT – explanations of the existence of currently unexplained harmonics. Estimates no longer required?
 - The concept of **THD+N** (Total Harmonic Distortion plus Noise) experienced with Low Frequencies could possibly be further explained – the symbiotics between shape and music (Cymatics).
 - **Jay Hambidge** could have applied this theory in his *Dynamic Symmetry* Theory. ($\sqrt{2}, \sqrt{2}, \sqrt{2} \dots$)
 - My **Quadrature** can be seen in a new light if we overlook ‘*area*’. ($\sqrt{2}, \sqrt{2}, \sqrt{2} \dots$)
 - Perhaps an enlightened view of **David Fowler’s** (and **Wilbur Knorr’s**) Anthypharesis Theory.
 - Could **Chun Ti Chang** of Cornell Uni have improved his analysis of *Constrained Sessile Drops* with an improved and expanded version of this knowledge of shape and frequency?
 - Could this theory be developed into a laboratory reference work?
 - Could **Wave Theory** be enhanced by this Shape Theory?
 - **David Attenborough** would make fine use of this theory especially in episodes such as his *Puffer Fish Love Nest* and plant roots responding to frequencies.
 - **Jack Kassewitz** in Florida USA is attempting to understand ‘*Dolphin Speak*’ by analyzing dolphin sounds cymatically; the one thing missing from his work is a system of maths that is applicable to this type of analysis.
 - **John Stuart Reid** in the U.K. would also benefit in these applications using his *CymaScope*.
 - **Resonance** studies would benefit from this theory;
 - **Alexander Lauterwasser** in producing his book “*Water Sound Images*” would have known that the *circles produced by Nature* within each of his photographs were actually the Inner or Outer or Intermediate Circles applicable to the Plane Regular Shape harmonics present in his images.
 - **Dr. Hans Jenny** obtained *results* in his experiments that I have *theorised* from my maths.
 - **Alexander Lauterwasser** with his perfect high resolution images has captured the method of analyzing these shapes; Nature is obviously not hiding these Circles from us.
 - **Dr. Sungchul Ji** should be keen to obtain this knowledge *before* he uses a Cymascope in his biological cell research; he should be aware of the Ratios of Plane Regular Shape.
 - The physicists at Bulgaria too. MORE Quantum use of audible freq agitation.
 - **We would all** realise that *Mother Nature* knows this form of Mathematics so perfectly that she includes *visual examples of the applicable circles* in many Cymatics results. These circles can discern whether the resulting shape is a 10 point polygram or two pentagrams in phase.
 - **Dr. Brian Greene** might just find the harmonies and the patterns that he seeks.

- Cymatic analysis of the correlation between Music and Shape leads to a suggestion that shape could exist in the scale of Frequency in the Very Low and Ultra Low Frequency areas. (In areas where low frequency noise is experienced and specifically **filtered out** of equipment.) SO:-
 - **Is** shape a frequency?
 - Does shape merely **act like** a frequency?
 - Is shape something else that **responds** to frequency?
 - Is shape symbolic of the agitation of electrons whose **paths are altered** by frequency?
- With the exception of the integer **2** and its integer multiples (and squares and square roots thereof) all plane regular shape ratios are incommensurable numbers.
 - Are those incommensurable ratios that give us shape **reserved solely for shape** in the spectrum of frequencies (if shape is a frequency)?
 - Can other entities **share** an incommensurable ratio with a shape? (**$\sqrt{2}$** and multiples excluded).
 - How many entities contain **2** and **$\sqrt{2}$** as major harmonic multipliers?
 - Do the **incommensurable values** of Music, Shape and Square Roots (*all with 2 and $\sqrt{2}$ as major harmonic multipliers*) and other physical entities reside alongside each other in the spectrum with **unallocated values** becoming background microwave radiation?
- A new graphical perspective and a unique equation could now be given to the Golden Mean which is possibly now also the ratio for a plane regular shape. (The Inner Septagram?)

Analysis of Harmonics: - Undertones and Overtones:

- Just as music notes can generate *undertones*, shapes also contain *harmonic 'undertones'*. E.g. the 12 pointed polygram actually contains 3 squares (ratio $\sqrt{2}$) and 4 equilateral triangles (ratio 2) within its outline. These are what I call **Construction Harmonics**.
- When the note or frequency that produces the 12 point polygram cymatically is played it is necessary to refine and extract from the results the undertone frequencies for these *undertone shapes*.
- Undertones for Music are deemed to be *in an Arithmetic and Integer relationship* with the fundamental frequency. Shapes seem to produce undertones which are in a *Harmonic relationship* with the fundamental shape. Calculation of Harmonic relationships of shape ratios require multiplication or division, not addition or subtraction.
- Are **shape undertones** that are found in Cymatic experiments indicative of the **music to shape** relationship?
 - If Music and Shape correlate then are the **musical undertones** found in the cymatically displayed note those that produce the known **shape undertones** of the required resulting shape?
 - Would this explain problems experienced by UK's John Stuart Reid in his attempt to illustrate 'Dolphin Speak' for Jack Kassewitz in Florida USA?
 - Would this explain the difficulty in obtaining precise results from tuning frequencies and amplitudes in cymatics experiments?
 - Would this explain the variances between Reid's results for the first two octaves of the piano and my attempt to align Music frequency with shape ratios? I **know** they correlate mathematically.
 - Would this assist those attempting to explain vibrations in major electrical generating equipment?
 - Would this remove the necessity to use **estimates** in Fourier Fast Transforms?
 - Does **amplitude** define whether a whole primary shape is displayed in a Cymatics experiment or whether we are seeing only the inner circle with perhaps one or two intermediate ones?

Shape Ratios do not require a Unit of Measurement:

- Regardless of physical size a square will always have a ratio of $\sqrt{2}$.
 - $\sqrt{2}$ will always be the ratio for the Equilateral triangle.
 - $\sqrt{5} - 1$ will always be the ratio for the Pentagon.
 - $\sqrt{5} + 1$ will always be the ratio for the Pentagram. (NOT Φ as we are led to believe).
 - Note that these last two are *square roots +/- 1*. They are therefore not entities sharing a ratio.
- Perhaps these ratios, **requiring no unit of measurement**, can indicate a way to reconcile quantum theory with relativity.
- Perhaps the two concentric circles that define each shape could be seen to represent the **strong** and **weak** forces giving shape to atoms of matter. The equation $E=MC^2$, by itself, does not allow for shape.
- When the Inscribing Circle equals the Circumscribing Circle the ratio of the circles is 1 – **the Singularity**, - (which is the ratio for the circles). *When the strong force equals the weak force . . .*
- When the size of the Inscribing Circle is greater than that of the Circumscribing Circle there then exists a relationship between the circles which produces shape ratios that are the reciprocals of those on the other side of the Singularity. These reciprocal ratios are *Dark (or Anti) Matter* being less than 1.
- **There is no zero in this theory.** There is no “nothing”. A “Universe from nothing” becomes meaningless.
- There is no beginning and no end . . . just positive and negative infinity.

The Universe and two – dimensional Circles:

- Black Hole formation relies heavily on circular structure. One can almost discern the presence of Inscribing, Intermediate and Circumscribing circles in their structure.
- The Rings of Saturn are a set of concentric circles.
- There are Spiral Galaxies. *In space these appear more as two dimensional than as three dimensional.*
- Rotations of Planets are more two-dimensional than three-dimensional.

Two Dimensional Shape versus Three Dimensional Shape:

- Since **Plato** introduced the five Regular Solids there has been little or no interest shown in two dimensional shapes. We have all accepted that **Euclid** had this area well covered. But, although Euclid used Inscribing and Circumscribing circles with his shapes he did not use them **both together at the same time in a ratio one to the other**. This is a very fine distinction which has far reaching results.
- Although **Kepler** used both Circumscribing and Inscribing Circles together at the same time and seemed to be aware of the existence of some type of harmonics within the circuits of the planets he did not succeed in completely refining these harmonics. His harmonics consisted of ratios of certain whole integers. He fitted a plane shape ‘*plus a little more*’ between the circuits of the planets. I think this ‘*little more*’ is what I have refined as a Differential which I have found to contain a constant that enables shape ratios to sort square roots and music into order. I have not tried to refine Kepler’s ‘*little more*’ but I would hope that it could be done.
- **Kim Veltman**, a mathematician, has written an unpublished thesis on Plato’s Regular Solids which is what I call *the phone book of polyhedraphiliac mathematicians*. He has listed every person in the last 2500 years who dealt in any way with Plato’s 3 dimensional regular solids but none who dealt specifically with 2 dimensional plane regular shapes. He also champions “*Visual Mathematics*”.

Areas needing expansion and refinement in this theory:

- Correcting some *erroneous numbers* I have used to date which have some effect on the results. For example, for the ratio for the Octagram I had used Φ^2 or 2.618033991065290; for the Octagon I had used 1.0803630270: Unknowingly, I had made a compensating error for the correct ratios were 2.6131259297527620 and 1.082392200292390. When the incorrect ratios are multiplied they produce the quadrature ratio 2.82842712474619 (or $2 \times \sqrt{2}$) (or $\sqrt{2} \times \sqrt{2} \times \sqrt{2}$) (or $\sqrt{8}$). When the corrected ratios were multiplied they produced the same result!
- The correct **alignment** of music frequencies with shape ratios to correctly identify the cymatics.
- **Refining** methods in cymatic experiments (**Extra fine** frequency and amplitude tuning needed in equipment);
- **Refined frequency** selection is outside the range of normal proprietary equipment; my mathematics has been calculated to 15 decimal places; (*we are dealing with incommensurables*);
- **GOOD Signal Equipment** becoming more rare, obsolete and difficult to obtain creates an **emergency**; filtering out the low frequency noise in experiments would filter out some shapes.
- Cymatics (or, if you prefer, Modal Phenomena) should become a **full science** using this theory of shape, given that it is now capable of complying with a system of Maths;
- My numbers, by the very nature of the theory, rely upon each other for their harmonics; I made a grave error in my calculation of the ratios for the Octagram and Octagon and proceeded to produce ratios for 10 years. There is doubt now that Φ exists in any ratio. My Octagram's ratio was Φ^2 . My inner Septagram's ratio was Φ . Harmonics should still exist but the theory requires **re-enumeration**.

*If you think that Plane Regular Shape is already completely dealt with under the auspices of Geometry and Trigonometry then you are mistaken. These two branches of the sciences do not introduce **Shape Harmonics**. It seems to be that the Harmonics revealed through the **Ratios** of Plane Regular Shape address matters in Mathematics and Physics not otherwise accurately dealt with in these sciences.*

*There also seems to be a **relationship** between the harmonics in one entity and the harmonics in another entity. (Music – Shape – Square Roots of Integers – Planetary Motion – Nautical Creatures).*

*This is a totally new approach to this area of Mathematics and Physics and will not be found anywhere else. As it is a new approach I am aware that it will require time to be absorbed and assessed. There are no textbooks or references in existence. I can only refer to the work and theses of others who seem to be aware that they have something **missing** in the explanations for their frequency results. Their missing parameters can possibly be provided by this theory.*

***Adam Spencer**, one of the 'sleek geeks', in a recent (Aug 2015) Australian edition of Q&A on television stated that there seems to be a missing '**canonical**' mathematical theory. I am not saying that this theory is positively **it** but it is certainly missing from current mathematical content and is, I believe, a good candidate.*

*This area has been overlooked as we have developed Trigonometry and have rested upon our laurels safe in the belief that this area of Mathematics has been completely covered. **Ptolemy Claudius**, the father of Trigonometry, (though some claim Hippias), in 150ad developed his Chords to provide length measurements derived from angles of Polygons. He commenced with polygons as their angles were known at that time and the sides of the polygons became his chords. He merely estimated the chords for the angles in between using a rough method of harmonics based on integers. (30/29, 31/30, 32/31 . . .). At one point in his list of chords he threw all harmonics out the door and jumped 13 digits to arrive at a predetermined number.*

Unknown to him **he was the closest person in history to not discover this theory** although he did relate the harmonics of music to the planetary motions. I only discovered Ptolemy's proximity to this theory after 10 years of research and I had the book containing his chords on my shelf the whole time! With one simple extra step he could have related his polygons to complimentary polygrams. **His chord triangles, when inverted with the chord then lying along the diameter of his base (circumscribing) circle, provided the diameter for the inscribing circle for the complementary polygram.** The ratio of his chord (with a little refinement) to the diameter of his Circumscribing circle actually would have shown him these harmonics and we could have had them for the last 1865 years. Instead we inherited Trigonometry which seems to have satisfied our thirst for knowledge in this area ever since.

And this is just a brief Outline of the subject theory!

DAVID HILBERT

The program replaces an earlier, unachievable plan of action by the great mathematician **David Hilbert**, who in 1921 commanded mathematicians to weave infinity completely into the fold of finitistic mathematics.



Hilbert saw **finitistic reducibility** as the only remedy for the skepticism then surrounding the new **mathematics of the infinite**. As Simpson described that era, "There were questions about whether mathematics was going into a twilight zone."

The Rise of Infinity

The philosophy of infinity that Aristotle set out in the fourth century B.C. reigned virtually unchallenged until 150 years ago. **Aristotle accepted "potential infinity" — the promise of the number line (for example) to continue forever — as a perfectly reasonable concept in mathematics.** But he rejected as meaningless **the notion of "actual infinity,"** in the sense of a complete set consisting of infinitely many elements.

Aristotle's distinction suited mathematicians' needs until the 19th century. Before then, **"mathematics was essentially computational,"** said Jeremy Avigad, a philosopher and mathematician at Carnegie Mellon University. Euclid, for instance, deduced the rules for constructing triangles and bisectors — useful for bridge building — and, much later, astronomers used the tools of "analysis" to calculate the motions of the planets. **Actual infinity — impossible to compute by its very nature — was of little use.** But the 19th century saw a shift away from calculation toward conceptual understanding. Mathematicians started to invent (or discover) abstractions — above all, **infinite sets**, pioneered in the 1870s by the German mathematician **Georg Cantor**. "People were trying to look for ways to go further," Avigad said. Cantor's set theory proved to be a powerful new mathematical system. But such abstract methods were controversial. "People were saying, if you're giving arguments that don't tell me how to calculate, that's not math."

And, troublingly, the assumption that infinite sets exist led Cantor directly to some nonintuitive discoveries. He found that infinite sets come in an infinite cascade of sizes — a tower of infinities with no connection to physical reality. What's more, set theory yielded proofs of theorems that were hard to swallow, such as the 1924 Banach-Tarski paradox, which says that if you break a sphere into pieces, each composed of an infinitely dense scattering of points, you can put the pieces together in a different way to create two spheres that are the same size as the original. Hilbert and his contemporaries worried: Was infinitistic mathematics consistent? Was it true?

Amid fears that set theory contained an actual contradiction — a proof of $0 = 1$, which would invalidate the whole construct — math faced an existential crisis. The question, as Simpson frames it, was, "To what extent is mathematics actually talking about anything real? [Is it] talking about some abstract world that's far from the real world around us? Or does mathematics ultimately have its roots in reality?"

Amid questions over the consistency of infinitistic mathematics, the great German mathematician David Hilbert called upon his colleagues to prove that it rested upon solid, finitistic logical foundations

Wikipedia

Even though they questioned the value and consistency of infinitistic logic, Hilbert and his contemporaries did not wish to give up such abstractions — power tools of mathematical reasoning that in 1928 would enable the British philosopher and mathematician Frank Ramsey to chop up and color infinite sets at will. "No one shall expel us from the paradise which Cantor has created for us," Hilbert said in a 1925 lecture. He hoped to stay in Cantor's paradise and obtain proof that it stood on stable logical ground. **Hilbert tasked mathematicians with proving that set theory and all of infinitistic mathematics is finitistically reducible, and therefore trustworthy.** "We must know; we will know!" he said in a 1930 address in Königsberg — words later etched on his tomb.

However, the Austrian-American mathematician **Kurt Gödel** showed in 1931 that, in fact, we won't. In a shocking result, Gödel proved that no system of logical axioms (or starting assumptions) can ever prove its own consistency; to prove that a system of logic is consistent, you always need another axiom outside of the system. This means there is no ultimate set of axioms — no theory of everything — in mathematics. When looking for a set of axioms that yield all true mathematical statements and never contradict themselves, you always need another axiom. Gödel's theorem meant that Hilbert's program was doomed: ***The axioms of finitistic mathematics cannot even prove their own consistency, let alone the consistency of set theory and the mathematics of the infinite.*** This might have been less worrying if the uncertainty surrounding infinite sets could have been contained. But it soon began leaking into the realm of the finite. Mathematicians started to turn up infinitistic proofs of concrete statements about natural numbers — theorems that could conceivably find applications in physics or computer science. And this top-down reasoning continued. In 1994, Andrew Wiles used infinitistic logic to prove Fermat's Last Theorem, the great number theory problem about which Pierre de Fermat in 1637 cryptically claimed, "I have discovered a truly marvelous proof of this, which this margin is too narrow to contain." Can Wiles' 150-page, infinity-riddled proof be trusted?

With such questions in mind, logicians like Simpson have maintained hope that Hilbert's program can be at least partially realized. Although not all of infinitistic mathematics can be reduced to finitistic reasoning, they argue that the most important parts can be firmed up. Simpson, an adherent of Aristotle's philosophy who has championed this cause since the 1970s (along with Harvey Friedman of Ohio State University, who first proposed it), estimates that some 85 percent of known mathematical theorems can be reduced to finitistic systems of logic. "The significance of it," he said, "is that our mathematics is thereby connected, via finitistic reducibility, to the real world."

An Exceptional Case

Almost all of the thousands of theorems studied by Simpson and his followers over the past four decades have turned out (somewhat mysteriously) to be reducible to one of five systems of logic spanning both sides of the finite-infinite divide. For instance, Ramsey's theorem for triples (and all ordered sets with more than three elements) was shown in 1972 to belong at the third level up in the hierarchy, which is infinitistic. "We understood the patterns very clearly," said Henry Towsner, a mathematician at the University of Pennsylvania. "But people looked at Ramsey's theorem for pairs, and it blew all that out of the water."

QUANTUM LEAPS (if they exist) in FREQUENCY INDUCED PLANE REGULAR SHAPES

This chart has been produced as far as my current *GENOME OF SHAPE* will allow. A complete and accurate *GENOME OF SHAPE* would produce more accurate information. It is hoped that this minimal amount of info should give indications of possibilities.

| HARMONICS WITHIN THE 36 POINT PRIMARY POLYGRAM (10 DEGREES) | | | | | | | | | |
|--|---------------------|-----------------------------------|---------------------------------|---------|-----------------------|------------------------------------|-----------------------------|-------|--|
| MATHEMATICAL HARMONICS | | SHAPE x SHAPE = SHAPE | | | | | | | |
| <i>QUANTUM LEAPS (if they exist) in FREQUENCY INDUCED PLANE REGULAR SHAPES</i> | | | | | | | | | |
| | Quantum jump one | SHAPE | Quantum jump two | SHAPE | Quantum jump three | SHAPE | Quantum jump four | SHAPE | |
| | A x B | | A x B x C | | A x B x C x D | | A x B x C x D x E | | |
| A | 1.468084816 | | | | | | | | |
| B | 1.312328929 | 1.926610173 40pts 63deg | | | | | | | |
| C | 1.232948500 | 1.618033984 7pts φ 77.14285714deg | 2.375411123 50deg 36pts 2.38095 | | | | | | |
| D | 1.190710567 | 1.468084807 86deg | 1.926610162 40pts 63deg | | | 2.828427125 13pts 41.53846154deg | | | |
| E | 1.144122806 | 1.362319114 71pts (95.0704 deg) | 1.679669308 74deg | | | 2.204278624 54deg 20pts 2.21296est | 3.236067977 36deg pentagram | | |
| F | #VALUE! | #VALUE! | #VALUE! | | | #VALUE! | | | |
| G | #VALUE! | #VALUE! | #VALUE! | | | #VALUE! | | | |
| H | 1.080363027 | #VALUE! | #VALUE! | | | #VALUE! | | | |
| I | 1.080363026 | 1.16718427 40pts 117deg | #VALUE! | | | #VALUE! | | | |
| J | 1.049315779 | 1.133641971 13pts 124.75 deg | 1.224744871 109deg 1.2299165 | | | #VALUE! | | | |
| K | #VALUE! | #VALUE! | #VALUE! | | | #VALUE! | | | |
| L | #VALUE! | #VALUE! | #VALUE! | | | #VALUE! | | | |
| M | 1.020156459 | #VALUE! | 157.5 deg 16 sided gon | #VALUE! | | #VALUE! | | | |

| MATHEMATICAL HARMONICS | | QUANTUM LEAP FROM ONE MATHEMATICAL HARMONIC TO THE NEXT | |
|-------------------------------|---------------------|--|--------------------|
| | Quantum jump one | | SHAPE |
| | A / B | | |
| A | 1.468084816 | | |
| B | 1.312328929 | 1.118686622 | ----- |
| C | 1.232948500 | 1.064382599 | ----- |
| D | 1.190710567 | 1.03547288 | ----- |
| E | 1.144122806 | 1.040719196 | 45pts 148 deg |
| F | #VALUE! | #VALUE! | ----- |
| G | #VALUE! | #VALUE! | ----- |
| H | 1.080363027 | #VALUE! | ----- |
| I | 1.080363026 | 1 | <i>Singularity</i> |
| J | 1.049315779 | 1.029588087 | ----- |
| K | #VALUE! | #VALUE! | ----- |
| L | #VALUE! | #VALUE! | ----- |
| M | 1.020156459 | #VALUE! | ----- |

**3 x 12 POINT POLYGRAM IN PHASE
MATHEMATICAL HARMONIC MULTIPLIERS**

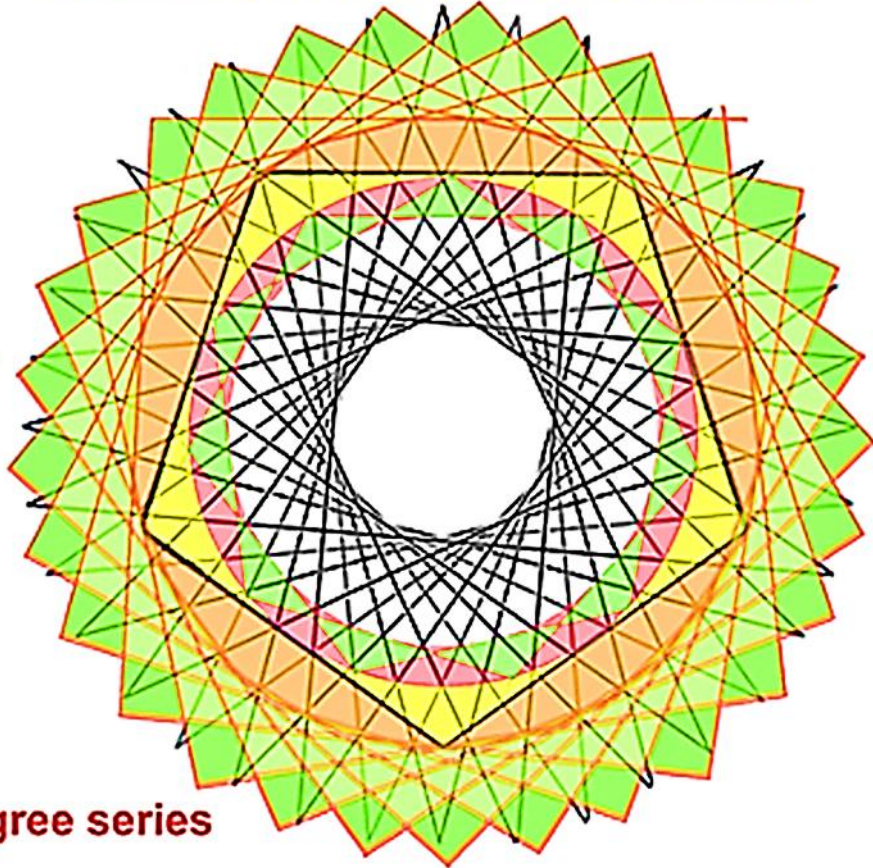

10 degree series

**Base Shape
3 x 12 points
36 Points 30°**

CONSTRUCTION HARMONIC MULTIPLIERS

3 x 12 Point Polygrams in phase with sides extended in stages:

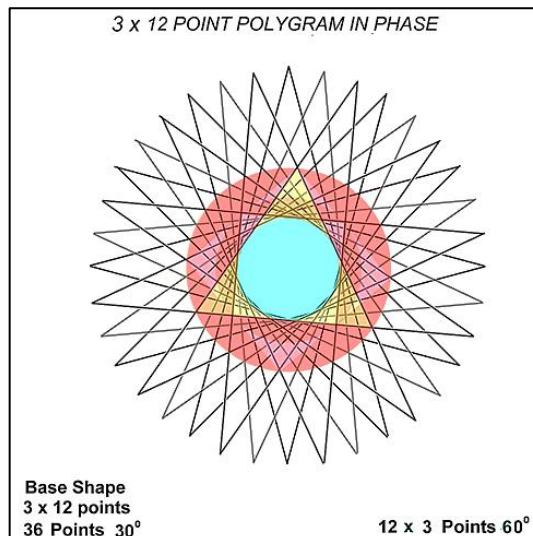
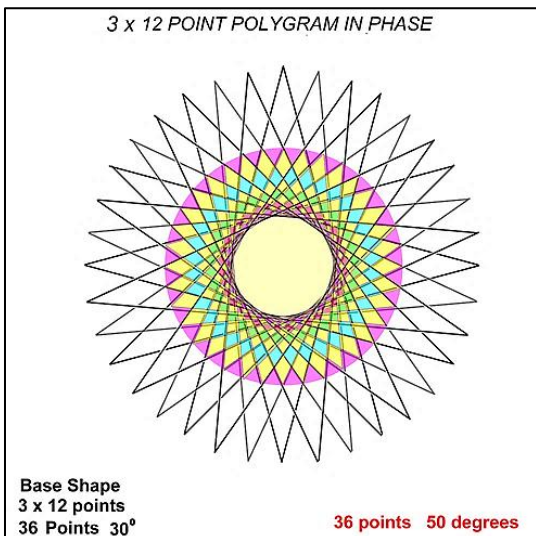
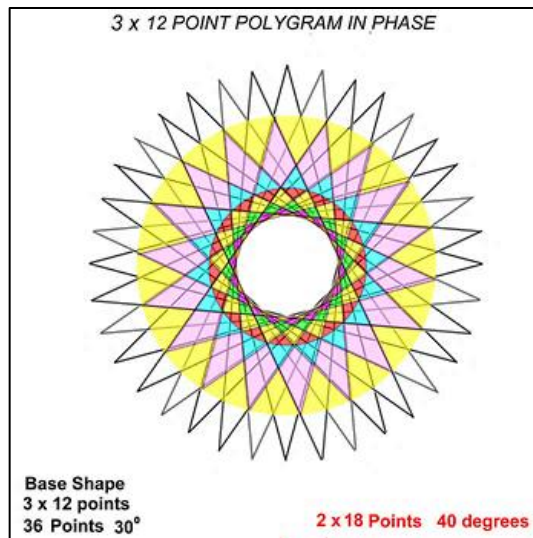
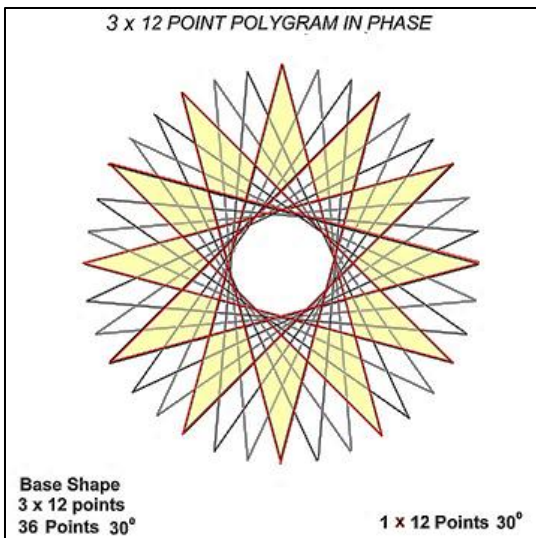
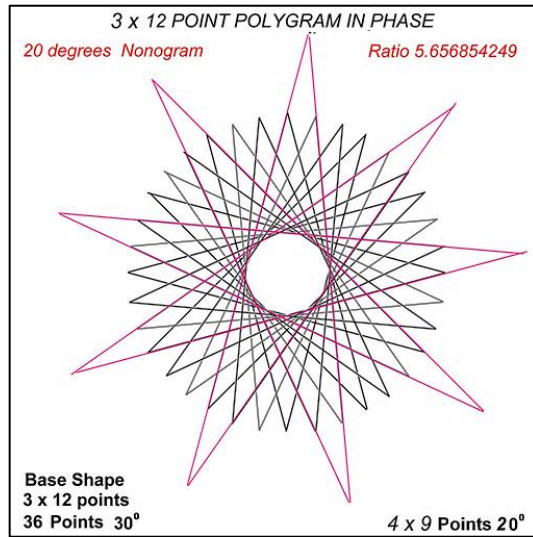
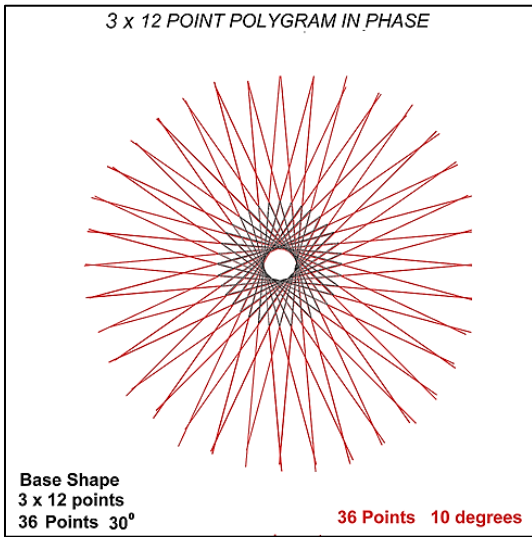

MATHEMATICAL HARMONIC MULTIPLIERS

THE INVISIBLE SHAPES THAT MAY INFLUENCE THE RATIO

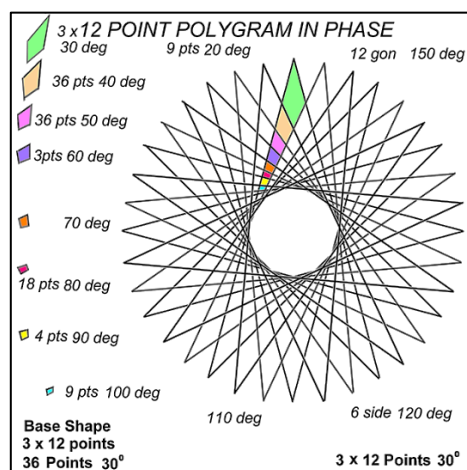
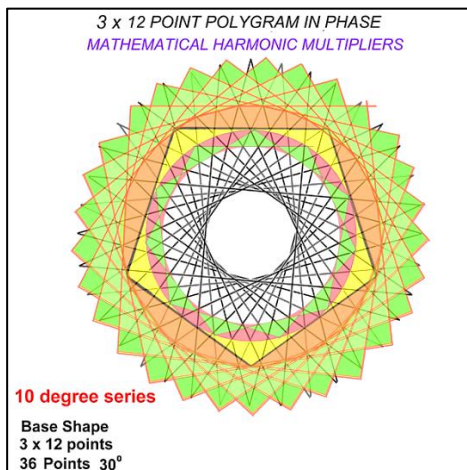
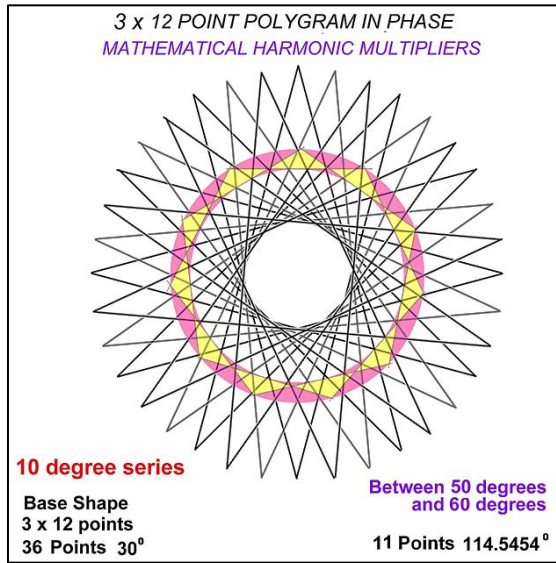
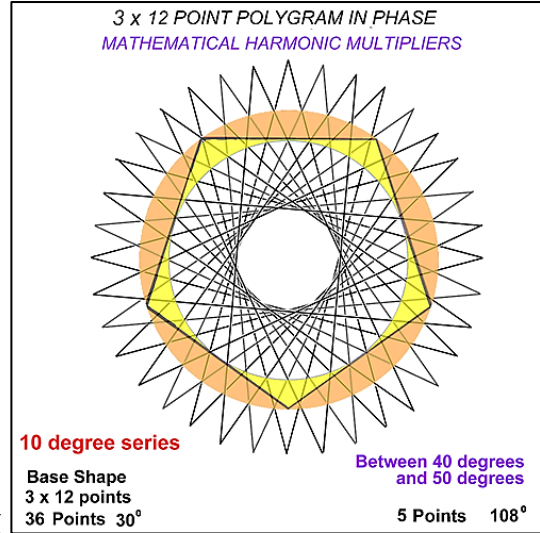
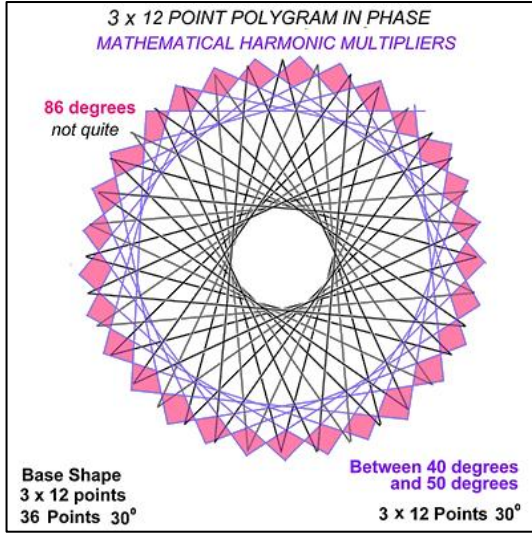

Shape to Music Correlation:

I have sought this elusive concept for several years. Its solutions continue to elude me. I have come close enough to state with a degree of certainty that this correlation does in fact exist; though I have not yet been able to illustrate it with total accuracy.

| SHAPE TO MUSIC CORRELATION | | | | SORTED | | Refined | |
|----------------------------|------------------|----------------------------------|-------------------------------------|-------------------|-------------------|---------------------------------------|--------------------|
| SHAPE | Note | Music | Shape Ratios | Shape | Shape / Music | Differential | DIFFERENTIALS |
| | | NEW, Freq, Hz hz / 100 Linear | Ratios including refined results | | | | |
| | | Refined | (nearest above) | | | | 10,000,000,000,000 |
| | | Linear | Harmonic | | | | |
| 41pts 22deg | F ₄ # | 7.399888454233780 | 7.404918347287620 | 1.059016994374940 | 1.000679725523560 | Note the differences between the sets | |
| | C ₄ | 5.232511306012600 | 5.236067977499760 | 1.059016994374940 | 1.000679725523590 | 1.000000000000030 | |
| | F ₃ # | 3.699944227116690 | 3.702459173643810 | 1.059016994374940 | 1.000679725523610 | 1.000000000000030 | |
| Octogram | C ₃ | 2.616255653006160 | 2.618033988749880 | 1.059016994374940 | 1.000679725523640 | 1.000000000000030 | |
| | F ₂ # | 1.849972113558250 | 1.851229586821910 | 1.059016994374940 | 1.000679725523670 | 1.000000000000030 | |
| Inner Nonogram | C ₂ | 1.308127826503010 | 1.309016994374940 | 1.059016994374940 | 1.000679725523690 | 1.000000000000030 | |
| | F ₄ | 6.984564628661070 | 6.992256391181140 | 1.020156458951420 | 1.001101251535210 | 1.000421239684150 | 1.000421239684150 |
| | B ₄ | 4.938833012561810 | 4.944271909999160 | 1.020156458951420 | 1.001101251535230 | 1.000000000000030 | |
| 30pts 48deg | F ₃ | 3.492282314330350 | 3.496128195590570 | 1.020156458951420 | 1.001101251535260 | 1.000000000000030 | |
| | B ₃ | 2.469416506280770 | 2.472135954999580 | 1.020156458951420 | 1.001101251535290 | 1.000000000000030 | |
| | F ₂ | 1.746141157165080 | 1.748064097795280 | 1.020156458951420 | 1.001101251535310 | 1.000000000000030 | |
| Pentagon | B ₂ | 1.234708253140320 | 1.236067977499790 | 1.020156458951420 | 1.001101251535340 | 1.000000000000030 | |
| | D ₄ | 5.873295358348910 | 5.990704784914500 | 1.059016994374940 | 1.019990383490370 | 1.018868353152150 | 1.000000000000030 |
| 41pts 57.07deg | G ₃ # | 4.153046975799880 | 4.236067977499750 | 1.059016994374940 | 1.019990383490400 | 1.000000000000030 | |
| | D ₃ | 2.936647679174300 | 2.995352392457270 | 1.059016994374940 | 1.019990383490430 | 1.000000000000030 | |
| | G ₂ # | 2.076523487899830 | 2.118033988749880 | 1.059016994374940 | 1.019990383490450 | 1.000000000000020 | |
| 15pts | D ₂ | 1.468323839587070 | 1.497676196228630 | 1.059016994374940 | 1.019990383490480 | 1.000000000000020 | |
| | G ₁ | 7.839908719636170 | 8.000000000000000 | 1.080363026950910 | 1.020420043917460 | 1.000421239684180 | 1.000421239684180 |
| Nonogram | C ₄ # | 5.543652619538130 | 5.656854249492380 | 1.080363026950910 | 1.020420043917480 | 1.000000000000030 | |
| 31pts 29deg | G ₃ | 3.819954359817880 | 4.000000000000000 | 1.080363026950910 | 1.020420043917510 | 1.000000000000030 | |
| Stonehenge | C ₃ # | 2.771826309768920 | 2.828427124746190 | 1.080363026950910 | 1.020420043917540 | 1.000000000000030 | |
| Equi Tri | G ₂ | 1.959977179908830 | 2.000000000000000 | 1.080363026950910 | 1.020420043917570 | 1.000000000000030 | |
| Square | C ₂ # | 1.385913154884390 | 1.414213562373100 | 1.080363026950910 | 1.020420043917590 | 1.000000000000030 | |
| | E ₄ | 6.592551138258310 | 6.854101966249600 | 1.059016994374940 | 1.03967368969760 | 1.018868353152150 | 1.018868353152150 |
| Decagram | A ₁ # | 4.661637615181420 | 4.846581979279140 | 1.059016994374940 | 1.03967368969790 | 1.000000000000030 | |
| | E ₃ | 3.296275569128980 | 3.427050983124800 | 1.059016994374940 | 1.03967368969820 | 1.000000000000030 | |
| | A ₃ # | 2.330818807590580 | 2.423290989639570 | 1.059016994374940 | 1.03967368969840 | 1.000000000000030 | |
| | E ₂ | 1.648137784564400 | 1.713525491562400 | 1.059016994374940 | 1.03967368969870 | 1.000000000000030 | |
| | A ₂ # | 1.165409403795230 | 1.211645494819790 | 1.059016994374940 | 1.03967368969900 | 1.000000000000030 | |
| Septagram | D ₄ # | 6.222539674442450 | 6.472135954999560 | 1.080363026950910 | 1.040111641486560 | 1.000421239684150 | 1.000421239684150 |
| Pentagram | A ₄ # | 4.400000000000470 | 4.576491222541460 | 1.080363026950910 | 1.040111641486580 | 1.000000000000030 | |
| 45pts 52deg | D ₃ # | 3.111269837221060 | 3.236067977499770 | 1.080363026950910 | 1.040111641486610 | 1.000000000000020 | |
| Golden Mean | A ₃ | 2.200000000000120 | 2.288245611270730 | 1.080363026950910 | 1.040111641486640 | 1.000000000000030 | |
| Hexagon | D ₂ # | 1.555634918610450 | 1.618033988749890 | 1.080363026950910 | 1.040111641486670 | 1.000000000000020 | |
| | A ₂ | 1.100000000000000 | 1.144122805635360 | 1.080363026950910 | 1.040111641486690 | 1.000000000000030 | |

DARK MATTER AND BLACK HOLES

SHAPE X SHAPE = SHAPE

| REFINING THE RATIOS ASSUMING THAT THE SHAPE THEORY HOLDS .. AND 8 GON, 8 GRAM, 12 GON, 12 GRAM, AND HEXAGON AND DECAGRAM ARE CORRECTED TO 15 PLACES | | | | | | |
|---|-------------------|-------------------|-------------------|-------------------|-------------------|-------------------|
| <i>MULTIPLICATION MATRIX</i> | | octogon | HEXAGON | pentagon | inner nonogram | Square |
| octogon | 1.082392200292390 | 1.082392200292390 | 1.154700538379250 | 1.236067977499790 | 1.306562964876380 | 1.414213562373100 |
| HEXAGON | 1.154700538379250 | 1.171572875253800 | 1.249838856415130 | 1.337910337876970 | 1.414213562373100 | 1.530733729460360 |
| pentagon | 1.236067977499790 | 1.249838856415130 | 1.333333333333330 | 1.427288359092360 | 1.508688958969150 | 1.632993161855460 |
| inner nonogram | 1.306562964876380 | 1.337910337876960 | 1.427288359092360 | 1.527864045000420 | 1.615000641470880 | 1.748064097795290 |
| Square | 1.414213562373100 | 1.414213562373090 | 1.508688958969140 | 1.615000641470880 | 1.707106781186560 | 1.847759065022580 |
| DECAGRAM | 1.732050807568880 | 1.530733729460350 | 1.632993161855450 | 1.748064097795280 | 1.847759065022580 | 2.000000000000010 |
| 16pts | 1.847759065022580 | 1.874758284622690 | 2.000000000000000 | 2.140932538638540 | 2.263033438453720 | 2.449489742783190 |
| equilateral triangle | 2.000000000000000 | 1.999999999999990 | 2.133608387176710 | 2.283955810409360 | 2.414213562373100 | 2.613125929752760 |
| 30pts | 2.472135954999580 | 2.164784400584780 | 2.309401076758500 | 2.472135954999580 | 2.613125929752760 | 2.828427124746200 |
| octogram | 2.613125929752760 | 2.675820675753920 | 2.854576718184720 | 3.055728090000840 | 3.230001282941750 | 3.496128195590580 |
| Pentagram | 3.236067977499790 | 2.828427124746180 | 3.017377917938290 | 3.230001282941750 | 3.414213564179140 | 3.695518130045160 |
| | | 3.502694738461740 | 3.736689435850860 | 4.000000000000000 | 4.228126573460210 | 4.576491222541490 |

DOES DARK MATTER SHAPE X DARK MATTER SHAPE = SHAPE, IS THIS ALSO DARK MATTER? – (*MULTIPLICATION MATRIX*)

| REFINING THE RECIPROCAL RATIOS ASSUMING THAT THE SHAPE THEORY HOLDS .. AND THE RATIOS ARE CORRECTED TO 15 PLACES | | | | | | |
|--|-------------------|-------------------|-------------------|-------------------|-------------------|-------------------|
| <i>MULTIPLICATION MATRIX</i> | | octogon | HEXAGON | pentagon | inner nonogram | Square |
| octogon | 0.923879532511288 | 0.923879532511288 | 0.866025403784438 | 0.809016994374947 | 0.765366864730179 | 0.707106781186547 |
| HEXAGON | 0.866025403784438 | 0.853553390593276 | 0.800103145191266 | 0.747434242556813 | 0.707106781186548 | 0.653281482438188 |
| pentagon | 0.809016994374947 | 0.800103145191266 | 0.749999999999999 | 0.70062926922036 | 0.662827148071183 | 0.612372435695794 |
| inner nonogram | 0.765366864730179 | 0.747434242556814 | 0.70062926922036 | 0.654508497187473 | 0.619194800498186 | 0.572061402817684 |
| Square | 0.707106781186547 | 0.707106781186548 | 0.662827148071183 | 0.619194800498186 | 0.585786437626904 | 0.541196100146196 |
| DECAGRAM | 0.577350269189626 | 0.653281482438189 | 0.612372435695794 | 0.572061402817684 | 0.541196100146197 | 0.500000000000000 |
| 16pts | 0.541196100146195 | 0.534402096794178 | 0.500000000000000 | 0.467086179481358 | 0.441884765380789 | 0.408248290463863 |
| equilateral triangle | 0.500000000000000 | 0.499999999999999 | 0.468689571155672 | 0.437836842307718 | 0.414213562373093 | 0.382683432365088 |
| 30pts | 0.404508497187474 | 0.461939766255644 | 0.433012701892219 | 0.404508497187474 | 0.382683432365090 | 0.353553390593274 |
| octogram | 0.382683432365089 | 0.373717121278407 | 0.350314634611018 | 0.327254248593737 | 0.309597400249093 | 0.286030701408842 |
| Pentagram | 0.309016994374947 | 0.353553390593270 | 0.331413574035591 | 0.309597400249093 | 0.292893218813452 | 0.270598050073098 |
| | | 0.285494476301170 | 0.267616567329817 | 0.250000000000000 | 0.236511368133097 | 0.218508012244410 |

MATTER SHRINKING DOWN INSIDE THE BLACK HOLE?

IF SHAPE X SHAPE = SHAPE, IS THIS DARK MATTER? – (*DIVISION MATRIX*)

| REFINING THE RATIOS ASSUMING THAT THE SHAPE THEORY HOLDS .. AND 8 GON, 8 GRAM, 12 GON, 12 GRAM, AND HEXAGON AND DECAGRAM ARE CORRECTED TO 15 PLACES | | | | | | |
|---|-------------------|-------------------|-------------------|-------------------|-------------------|-------------------|
| <i>DIVISION MATRIX</i> | | octogon | HEXAGON | pentagon | inner nonogram | Square |
| octogon | 1.082392200292390 | 1.082392200292390 | 1.154700538379250 | 1.236067977499790 | 1.306562964876380 | 1.414213562373100 |
| HEXAGON | 1.154700538379250 | 0.999999999999997 | 1.066804193588350 | 1.141977905204680 | 1.207106781186550 | 1.306562964876380 |
| pentagon | 1.236067977499790 | 0.937379142311344 | 0.999999999999998 | 1.070466269319270 | 1.131516719226860 | 1.224744871391590 |
| inner nonogram | 1.306562964876380 | 0.875673684615435 | 0.934172358952714 | 1.000000000000000 | 1.057031642805910 | 1.144122805635370 |
| Square | 1.414213562373100 | 0.828427124746185 | 0.883769530761575 | 0.946045472532386 | 1.000000000000000 | 1.082392200292390 |
| DECAGRAM | 1.732050807568880 | 0.765366864730177 | 0.816496580927725 | 0.874032048897642 | 0.923879532511289 | 1.000000000000000 |
| 16pts | 1.847759065022580 | 0.624919428207563 | 0.666666666666666 | 0.713644179546180 | 0.754344479484574 | 0.816496580927729 |
| equilateral triangle | 2.000000000000000 | 0.585786437626902 | 0.624919428207564 | 0.668955168938483 | 0.707106781186549 | 0.765366864730182 |
| 30pts | 2.472135954999580 | 0.541196100146195 | 0.577350269189625 | 0.618033988749895 | 0.653281482438190 | 0.707106781186550 |
| octogram | 2.613125929752760 | 0.437836842307718 | 0.467086179481357 | 0.500000000000000 | 0.528515821402954 | 0.572061402817686 |
| Pentagram | 3.236067977499790 | 0.414213562373093 | 0.441884765380788 | 0.473022736266194 | 0.500000000264489 | 0.541196100146198 |
| | | 0.334477584469240 | 0.356822089773089 | 0.381966011250105 | 0.403750160581293 | 0.437016024448823 |

MATTER REGENERATING DOWN THE BLACK HOLE?

REFINING THE RATIOS ASSUMING THAT THE SHAPE THEORY HOLDS .. AND THE RATIOS ARE CORRECTED TO 15 PLACES

| <i>DIVISION MATRIX</i> | | octogon | HEXAGON | pentagon | inner nonogram | Square |
|-------------------------------|-------------------|-------------------|-------------------|-------------------|-------------------|-------------------|
| | | 1.082392200292390 | 1.154700538379250 | 1.236067977499790 | 1.306562964876380 | 1.414213562373100 |
| octogon | 1.082392200292390 | 1.000000000000000 | 1.066804193588360 | 1.141977905204680 | 1.207106781186560 | 1.306562964876390 |
| HEXAGON | 1.154700538379250 | 0.937379142311345 | 1.000000000000000 | 1.070466269319270 | 1.131516719226860 | 1.224744871391600 |
| pentagon | 1.236067977499790 | 0.875673684615435 | 0.934172358962714 | 1.000000000000000 | 1.057031642805910 | 1.144122805635370 |
| inner nonogram | 1.306562964876380 | 0.828427124746185 | 0.883769530761575 | 0.946045472532386 | 1.000000000000000 | 1.082392200292390 |
| Square | 1.414213562373100 | 0.765366864730177 | 0.816496580927725 | 0.874032048897642 | 0.923879532511289 | 1.000000000000000 |
| DECAGRAM | 1.732050807568880 | 0.624919428207563 | 0.666666666666666 | 0.713644179546180 | 0.754344479484574 | 0.816496580927729 |
| 16pts | 1.847759065022580 | 0.585786437626902 | 0.624919428207564 | 0.66895168938483 | 0.707106781186549 | 0.765366864730182 |
| equilateral triangle | 2.000000000000000 | 0.541196100146195 | 0.577350269189625 | 0.618033988749895 | 0.653281482438190 | 0.707106781186550 |
| 30pts | 2.472135954999580 | 0.437836842307718 | 0.467086179481357 | 0.500000000000000 | 0.528515821402954 | 0.572061402817686 |
| octogram | 2.613125929752760 | 0.414213562373093 | 0.441884765380788 | 0.473022736266194 | 0.500000000264489 | 0.541196100146198 |
| Pentagram | 3.236067977499790 | 0.334477584469240 | 0.356822089773089 | 0.381966011250105 | 0.408750160581293 | 0.437016024448823 |

| | | | | | |
|------------------------------------|-------------------|-------------------|-------------------|-------------------|-------------------|
| | 1.000000000000000 | 0.937379142311345 | 0.875673684615435 | 0.828427124746185 | 0.765366864730174 |
| | 1.066804193588360 | 1.000000000000000 | 0.934172358962714 | 0.883769530761575 | 0.816496580927722 |
| RECIPROCAL OF ABOVE RESULTS | 1.141977905204680 | 1.070466269319270 | 1.000000000000000 | 0.946045472532386 | 0.874032048897639 |
| | 1.207106781186560 | 1.131516719226860 | 1.057031642805910 | 1.000000000000000 | 0.923879532511286 |
| REVEAL FURTHER SHAPE RATIOS | 1.306562964876380 | 1.224744871391590 | 1.144122805635370 | 1.082392200292390 | 0.999999999999996 |
| | 1.600206290382540 | 1.500000000000000 | 1.401258538444070 | 1.325654296142360 | 1.224744871391580 |
| | 1.707106781186560 | 1.600206290382530 | 1.494868485113630 | 1.414213562373090 | 1.306562964876370 |
| MY REASON TO CALL THEM DARK MATTER | 1.847759065022580 | 1.732050807568880 | 1.618033988749890 | 1.530733729460360 | 1.414213562373090 |
| | 2.283955810409360 | 2.140932538638540 | 2.000000000000000 | 1.892090945064770 | 1.748064097795280 |
| | 2.414213562373110 | 2.263033438453720 | 2.114063285611810 | 1.999999998942050 | 1.847759065022570 |
| | 2.989736970227260 | 2.802517076888150 | 2.618033988749890 | 2.476779200682580 | 2.288245611270730 |

I now introduce you to the magic thread:

A SIMPLE THEORY OF THE HARMONICS OF PLANE REGULAR SHAPE

THE UNSEEN RATIOS

This is a precis of the mathematics of Nature that underly the Theory:

- based on the most simple of concepts;
- hidden in plain sight;
- which have extremely widespread application;
- which have remained invisible to us for at least 5000 years;
- that could answer questions raised since the beginning of time;
- that, although they have really remained unseen, they have somehow been the basis for much science;

Observe Plane Regular Shapes to ascertain their common features:

Some Plane Regular Shapes – What is common to them all?

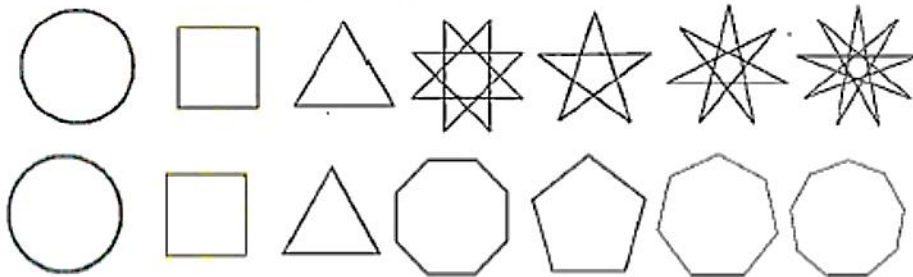

KINDERGARTEN TOYS or THE PLANE REGULAR SHAPES of NATURE?

- Polygons; Polygrams; the circle; the square; and the equilateral triangle.
- Note that they all have some common characteristics:
 - *Naturally, they are all two-dimensional.*
 - *Given, they are each of course equi-angular and equi-lateral.*
 - *They all can have Circumscribing **AND** Inscribing Concentric Circles delineating their outer and inner boundaries. (They are not solids and therefore they also have Inner boundaries.)*
 - *Each Shape has this pair of concentric circles present in a Ratio unique for that shape.*
 - *Physical size of a shape has no effect upon its Ratio – Ratios do not change with size changes.*
 - *These ratios co-exist in a set that displays incredible harmonics – the harmonics of Nature.*

The Harmonics that exist within Plane Regular Shape cannot be ascertained from the shapes themselves. Over the centuries many concepts have been illustrated purporting to represent the inner harmonics of some particular shape. They do not and could not purport to represent the harmonics between or within *ALL* Plane Regular Shapes. The only method that indicates the existence of a *system* within the harmonics of Plane Regular Shape is that which utilizes the comparison of the Shapes' Ratios derived from the relativity of the dimensions of each shape's Circumscribing Circle to its Inscribing Circle.

MY 'CIRCLE OF INNER HARMONY'

EXPERIMENTS

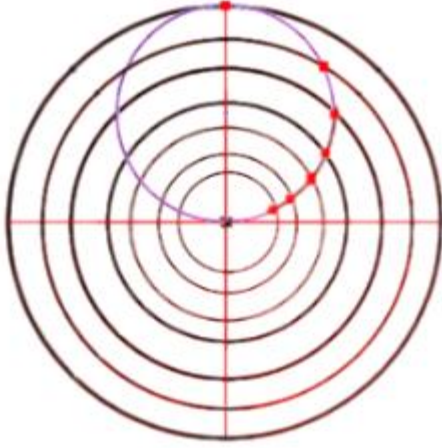

This part of my theory is based upon the calculations and images obtained when the basic tenet of this Shape Theory that '*physical size is irrelevant*' is overlooked and ignored to enable some comparisons between shapes to be made.

I had an urge to overlay some shapes transparently over each other using a Common Circumscribing Circle. This enabled me to "see" the loci of the right angles that are evident in the structure and geometry of the shapes.

THE LOCI OF THE RIGHT ANGLES INNPLANE REGULAR SHAPE:

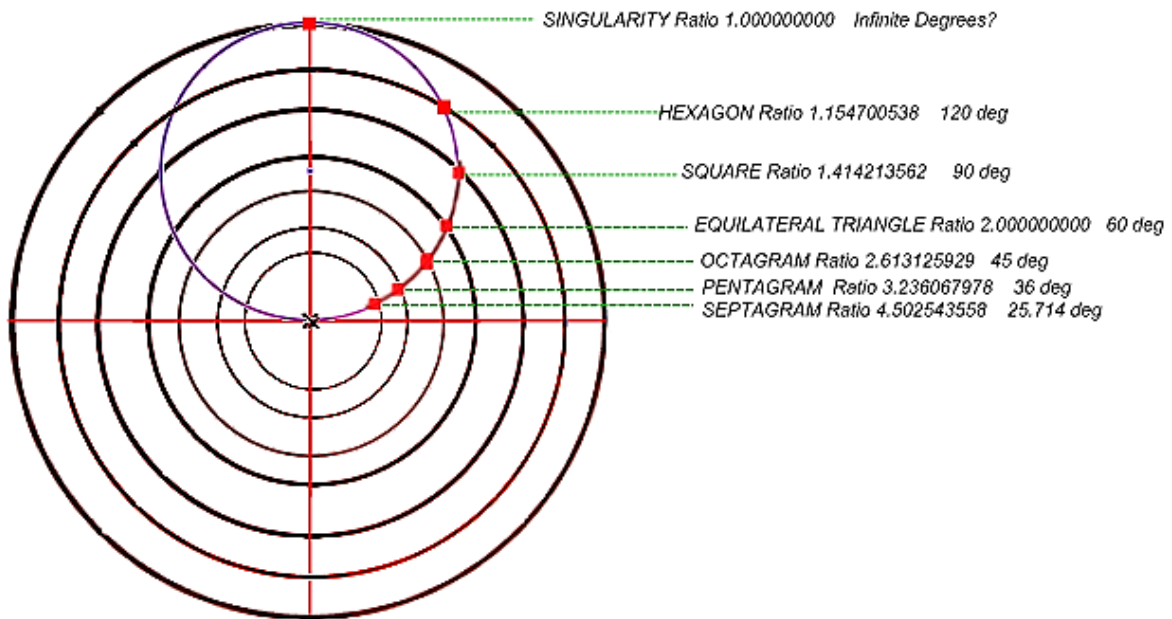

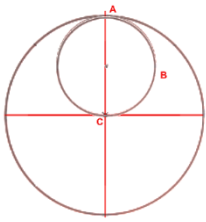

The locations of point "B" along the Inner Circle of Harmony for each shape where this circle intersects the Inscribing Circles for the Shapes.

Circle of Harmony intersecting the Inscribing Circles at point "B":

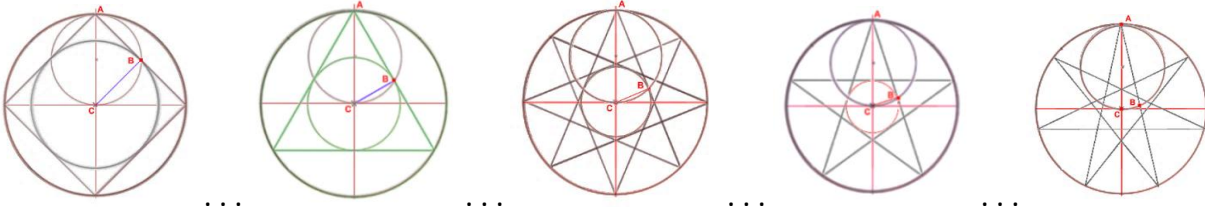

The locations of point "B" along the Inner Circle of Harmony for each shape where this circle bisects the Sides of the Shapes.

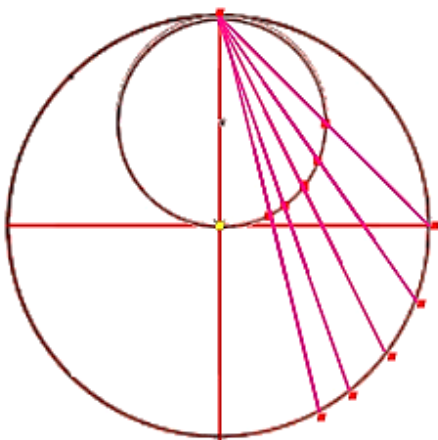
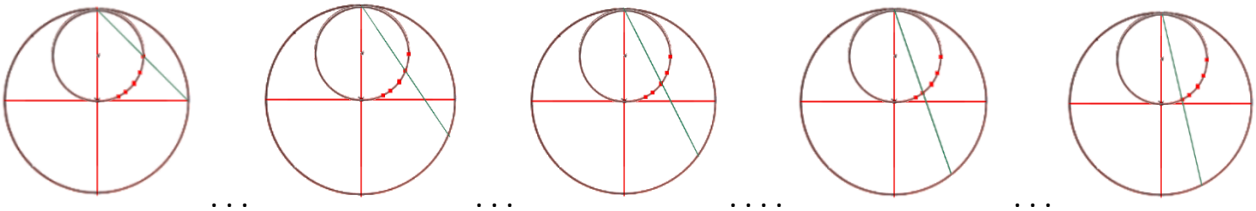

The *Ordered* manner in which the first side of each shape is bisected by the Inner Circle of Harmony on its journey to be reflected off the Circumscribing Circle to ultimately form its designated shape.

MY 'GENOME' OF SHAPE' (TO DATE)

| Deg | Shape | Ratio | Deg | Shape | Ratio |
|-----|------------------------|-------------------|-----|------------------------|-------------------|
| 1 | | | 91 | | |
| 2 | 16.000000000000000 | | 92 | 45pts est ratio | 1.386271242968660 |
| 3 | 14.809836694575200 | | 93 | | |
| 4 | 13.708203932499200 | | 94 | | |
| 5 | 11.313708498984800 | | 95 | 71pts (95.0704) | 1.362319110000000 |
| 6 | 10.472135954999500 | | 96 | 30pts | 1.349166667 |
| 7 | 9.152982445082920 | | 97 | 13pts 96.923deg | 1.335402142000000 |
| 8 | 8.472135954999500 | | 98 | 22pts 98.181818deg | 1.323746919000000 |
| 9 | 8.000000000000000 | 6.854101966249600 | 99 | 40pts | 1.315789474000000 |
| 10 | 6.992256391181140 | 7.404918347287620 | 100 | inner nonogram | 1.309016994000000 |
| 11 | | | 101 | | |
| 12 | 15 pt Primary polygram | 9.152982446 plus | 102 | | |
| 13 | 12.5 degrees ?pts | 9.152982446 | 103 | 14 pt polygram | 1.272019649514070 |
| 14 | | | 104 | | |
| 15 | | | 105 | | |
| 16 | | | 106 | | 1.253914971405500 |
| 17 | | | 107 | | 1.249431391 |
| 18 | 20pts | 6.472135954999560 | 108 | pentagon | 1.236067977499790 |
| 19 | 18.947 deg 38pts | 6.111456184000000 | 109 | | |
| 20 | 20 degrees nonogram | 5.656854249492380 | 110 | | 1.211645495722230 |
| 21 | | 5.545084971874640 | 111 | | |
| 22 | 16pts 22.5deg | 5.236067977499790 | 112 | 16pts 112.5deg | 1.205357143000000 |
| 23 | | 4.944271909999160 | 113 | | |
| 24 | 24 degrees 30pts | 4.846581983000000 | 114 | 11pts 114.545454 deg | 1.190710563000000 |
| 25 | septagram 25.7142857 | 4.576491223248880 | 115 | | 1.189207115002720 |
| 26 | | 4.321452107803630 | 116 | | |
| 27 | 40pts | 4.236067978000000 | 117 | 40pts | 1.167184270000000 |
| 28 | 45pts | 4.176904000000000 | 118 | | |
| 29 | 31pts 29.032258deg | 4.000000000000000 | 119 | | |
| 30 | 12pts | 3.853220324000000 | 120 | hexagon | 1.144122806000000 |
| 31 | 29pts 31.03448deg | 3.702459175000000 | 121 | | |
| 32 | 17pts 31.76470588deg | 3.629305232154990 | 122 | | |
| 33 | 33 degrees 120pts | 3.496128197000000 | 123 | | 1.127838485561680 |
| 34 | 34 degrees 37pts | 3.427050986000000 | 124 | 45pts est ratio | 1.131319763600000 |
| 35 | | 3.464101616000000 | 125 | 13pts 124.75 deg | 1.13333 +/- |
| 36 | pentagram | 3.236067977499790 | 126 | 20pts | 1.121516995000000 |
| 37 | | | 127 | | 1.111785940502840 |
| 38 | | | 128 | 7pts 128.5714 septagon | 1.104854344000000 |
| 39 | | 2.995352394225280 | 129 | | 0.000000000000000 |
| 40 | 18pts | 2.936169615 | 130 | | |
| 41 | 13pts 41.53846154deg | 2.828427124746190 | 131 | | |
| 42 | 56pts 41.78571429 | stonehenge | 132 | 15pts | 1.100+/- |
| 43 | 29pts | 2.772542489 | 133 | | 1.090507732665260 |
| 44 | | 2.724600000000000 | 134 | | |
| 45 | octogram | 2.613125930000000 | 135 | 8pts octagon | 1.082392200342570 |

MY 'GENOME' OF SHAPE' (TO DATE)

| Deg | Shape | Ratio | | Deg | Shape | Ratio |
|-----|-----------------------|-------------------|--|-----|------------------------|-------------------|
| 46 | | | | 136 | | |
| 47 | | | | 137 | | |
| 48 | 30pts | 2.472135954999580 | | 138 | | 1.069636763408670 |
| 49 | 11pts 49.0909090909 | 2.423290987000000 | | 139 | | 1.061997403745260 |
| 50 | 36pts | 2.380952381000000 | | 140 | 9pts nonogon | 1.059016995000000 |
| 51 | | 2.334368543059490 | | 141 | | 1.058198208485710 |
| 52 | 52 degrees 45pts | 2.288245610000000 | | 142 | | 1.054412604487850 |
| 53 | | | | 143 | | |
| 54 | 20pts | 2.212962963000000 | | 144 | 10pts decagon | 1.053333300000000 |
| 55 | 72pts | 2.180232558000000 | | 145 | | |
| 56 | ?? | 2.160726055 | | 146 | | |
| 57 | 41pts | 2.118033990000000 | | 147 | 147.375deg 11sided | 1.047142857000000 |
| 58 | | | | 148 | 45pts | 1.040719200441880 |
| 59 | | | | 149 | | |
| 60 | Equilateral Triangle | 2.000000000000000 | | 150 | 12 sided gon | 1.038092722000000 |
| 61 | | | | 151 | | |
| 62 | | | | 152 | 152.5deg 13sided | 1.033333000000000 |
| 63 | 40pts | 1.926610162000000 | | 153 | | |
| 64 | | | | 154 | 14sided gon | 1.031027796+/- |
| 65 | 72pts | 1.888543820000000 | | 155 | | 1.030532582573330 |
| 66 | 60pts | 1.851229586000000 | | 156 | 15 sided gon | 1.030+/- |
| 67 | 16pts 67.5deg | 1.847759066000000 | | 157 | 157.5 deg 16 sided gon | 1.020156458000000 |
| 68 | | 1.814652616077490 | | 158 | | |
| 69 | 13pts 69.23076923deg | 1.748064098502690 | | 159 | | 1.014438521517910 |
| 70 | 35pts | | | 160 | | 1.014242384554290 |
| 71 | 33pts 70.909090deg | | | 161 | | |
| 72 | 10pts decagram | 1.732050808000000 | | 162 | 20 sided gon | 1.0133333+/- |
| 73 | | 1.713525493000000 | | 163 | | |
| 74 | | | | 164 | 45 pts | |
| 75 | 24pts | 1.650647824000000 | | 165 | | |
| 76 | 76 degrees 45pts | | | 166 | | |
| 77 | 7pts φ 77.14285714deg | 1.618033989000000 | | 167 | | |
| 78 | 60pts | 1.572302755514850 | | 168 | | |
| 79 | | | | 169 | | |
| 80 | 80 degrees 18pts | | | 170 | | |
| 81 | 11pts 81.818181deg | 1.527864046000000 | | 171 | | |
| 82 | | | | 172 | 45 sided gon | |
| 83 | | | | 173 | | |
| 84 | 84 degrees 15pts | 1.497676197000000 | | 174 | | |
| 85 | | | | 175 | | |
| 86 | | | | 176 | | |
| 87 | 22.5deg series 45pt | 1.448274121000000 | | 177 | | |
| 88 | | | | 178 | | |
| 89 | | | | 179 | | |
| 90 | Square | 1.414213562373100 | | 180 | straight line | 1.000000000000000 |

EQUATIONS USING MATHEMATICAL SHAPES

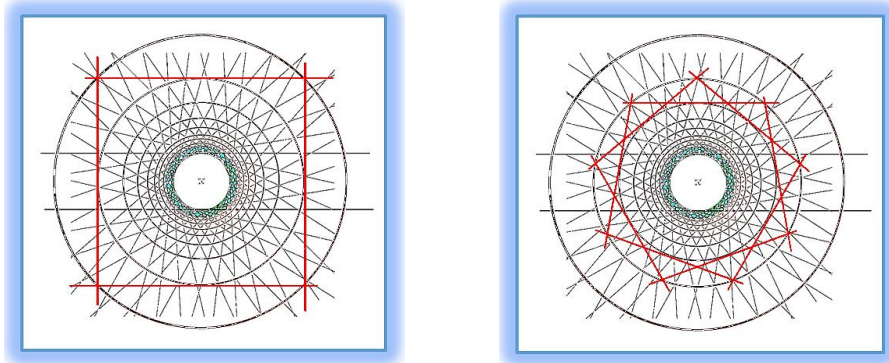

SQUARE – Ratio 1.414213562 X INNER NONOGRAM – Ratio 1.309016994374940
 1.414213562 X 1.309016994374940 = 1.851229586821910
 1.851229586821910 IS THE RATIO FOR A 60 POINT POLYGRAM WITH 66 DEGREES

The result is A 60 POINT POLYGRAM

Or 2 X 30 PT POLYGRAMS IN PHASE

Or 3 X 20 PT POLYGRAMS IN PHASE

Or 4 X 15 PT POLYGRAMS IN PHASE

Or 5 X 12 PT POLYGRAMS IN PHASE

or 6 X 10 PT POLYGRAMS IN PHASE

Only the circles and their ratio or the angles can identify the correct result.

Inner Nonogram 1.309016994374940 X Square 1.414213562
 = 1.851229586821910 = **60pts 66deg**

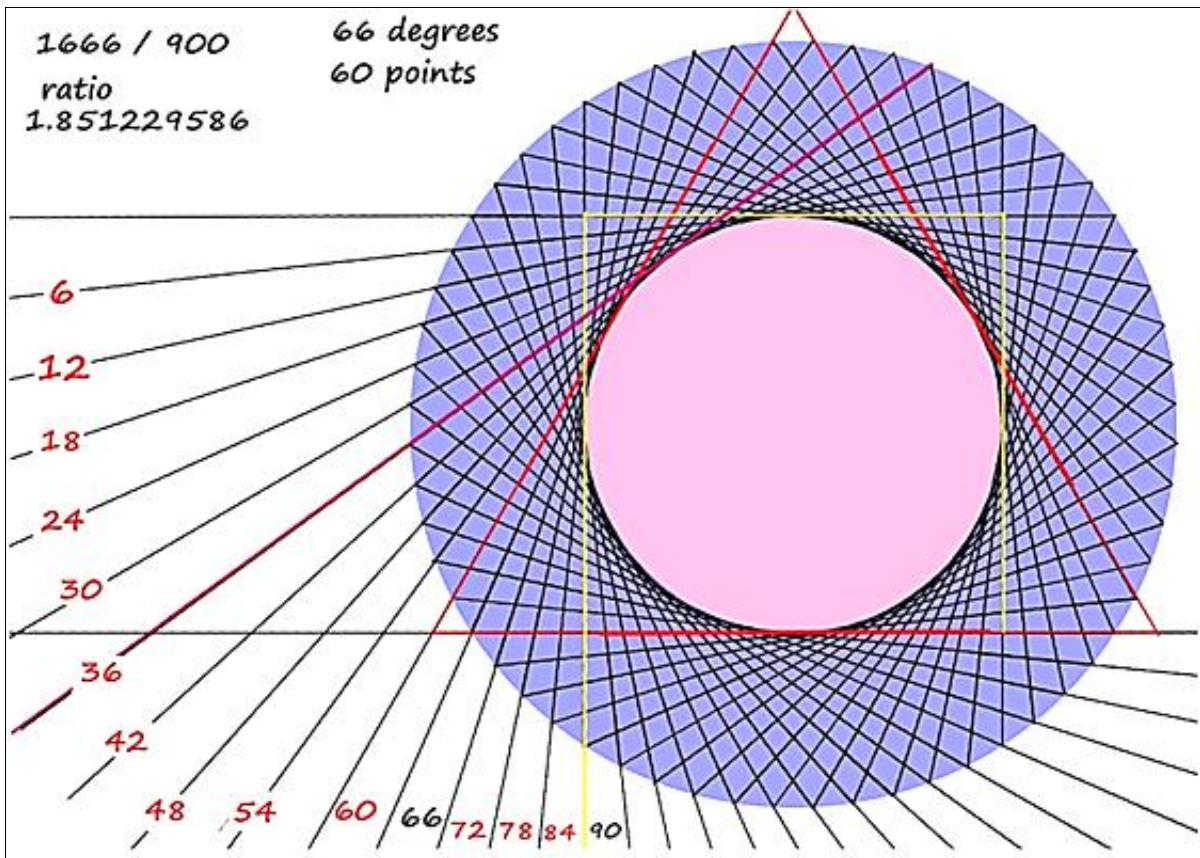

RELEVANT CIRCLES FOR 13 POINT POLYGRAM WITH RATIO 8.00000000

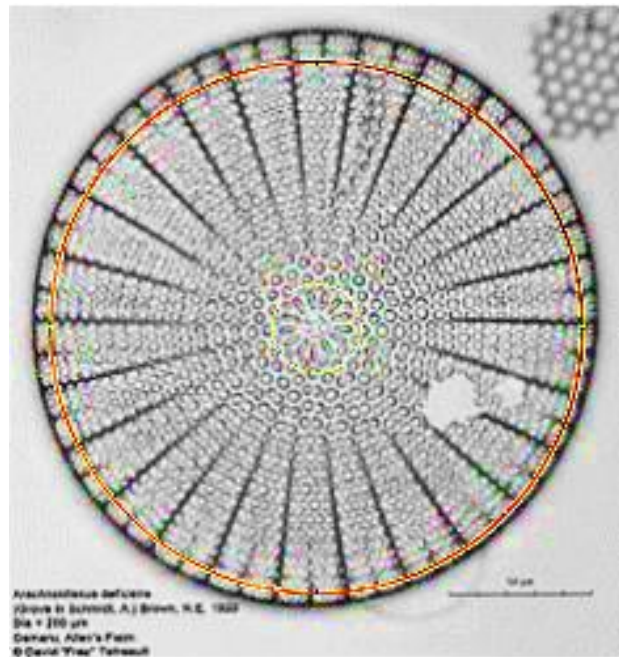
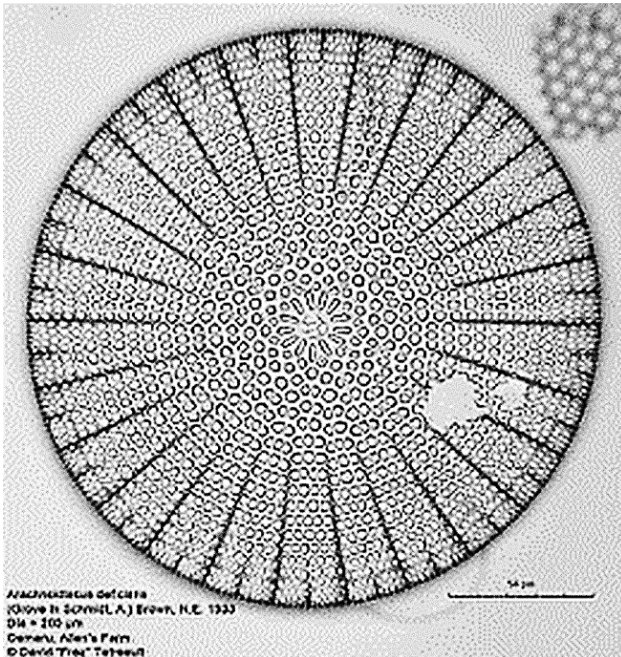

Regardless of the number of shapes that are present ***"In Phase"*** there remains but one pair of circles to define all these shapes. This pair of circles sets the ***"Ratio"*** for the shape and so a single shape or the four-***shapes-in-phase*** bear this same ratio. Knowing a shape's ratio is no indication that it will be a single shape or several shapes-in-phase.

Can you imagine a **13 point prime numbered** primary polygram residing in phase with itself (4 times) and thus disguised as a **52 point non-prime polygram**?

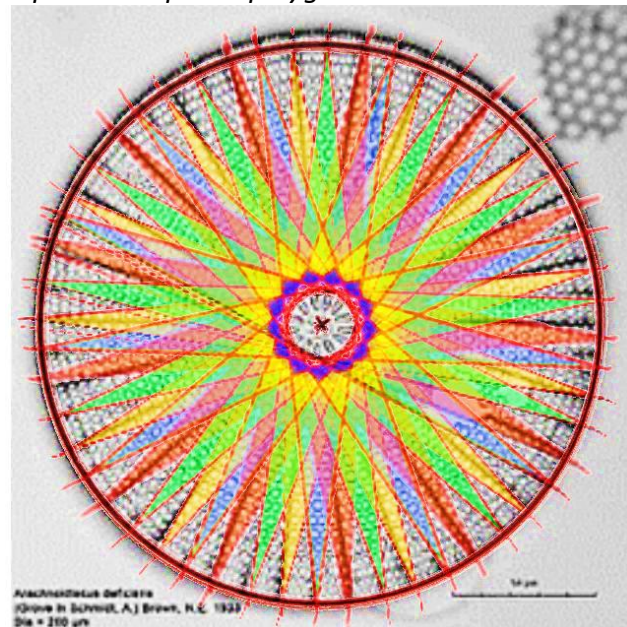
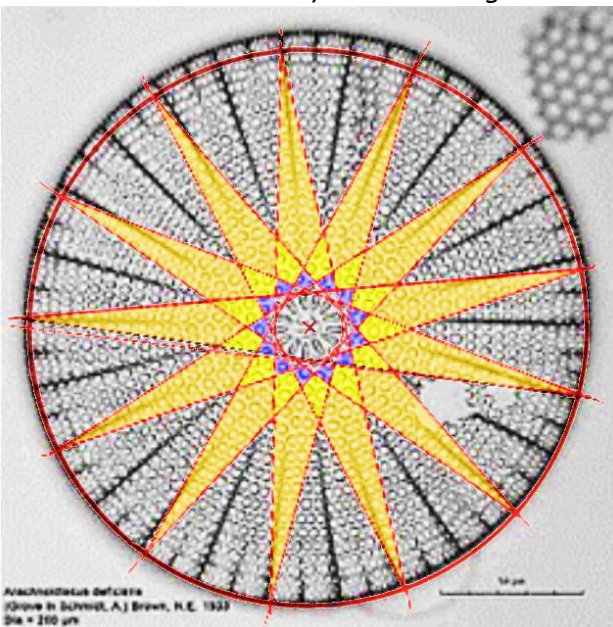

SINGLE PRIME SHAPE

FOUR PRIME SHAPES - IN - PHASE

BOTH OF THE ABOVE BEAR THE SAME RATIO.

AND NATURE SHOWS US THE CIRCLES AS WELL. (ALL ON A SINGLE CELLED DIATOM!)

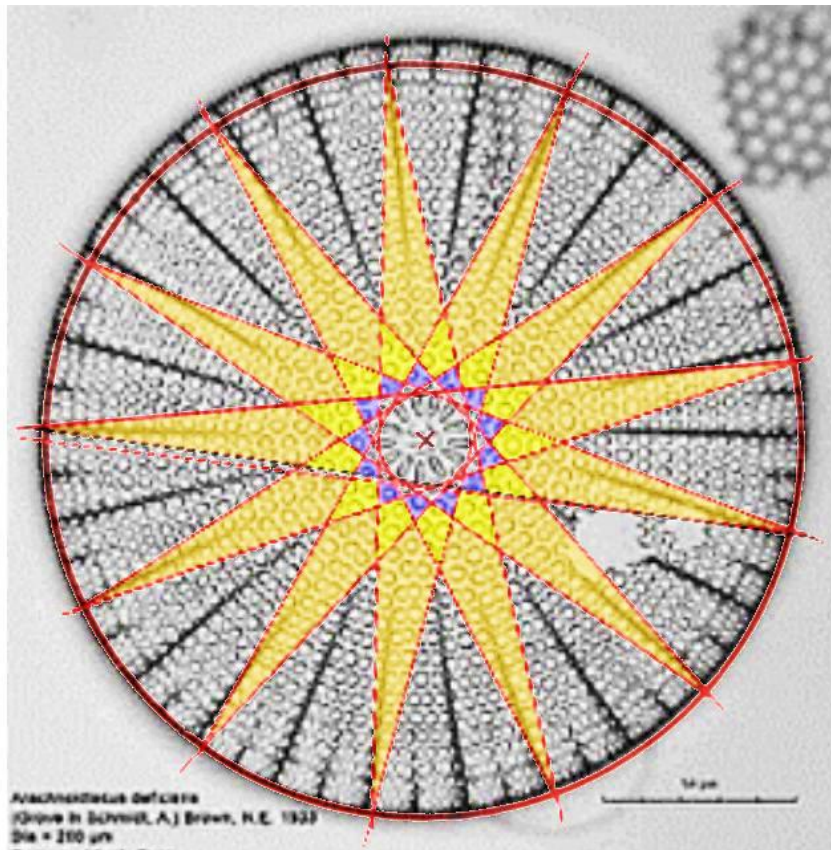

13 POINT PRIME NUMBERED PRIMARY POLYGRAM ratio **8.00000000**

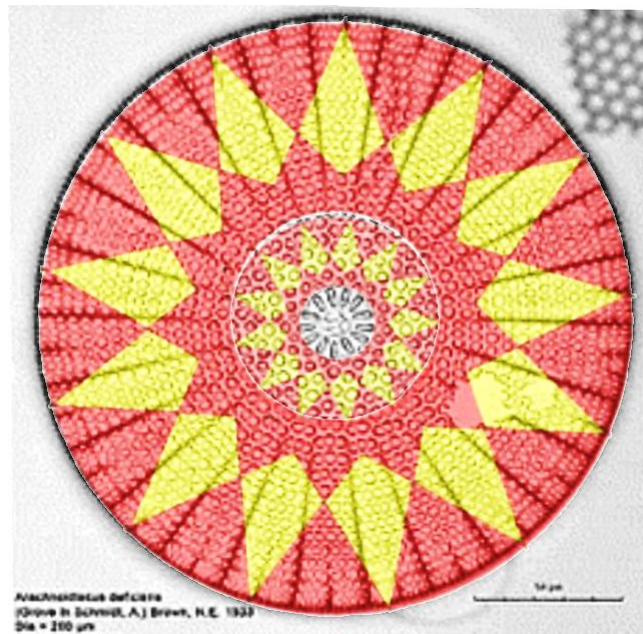

A 13 POINT PRIME NUMBERED POLYGRAM ratio **2.828427125 SQUARED** (Graphically).

THE RATIO FOR EACH OF THE SQUARED POLYGRAMS IS **2.828427125**, which, when squared, gives the ratio **8.00000000**, a number that produces the PRIME NUMBERED PRIMARY POLYGRAM BELOW.

A GOOD CANDIDATE FOR 2 PRIME SHAPES SQUARED IN NATURE.

THE 13 POINT PRIME NUMBERED PRIMARY POLYGRAM

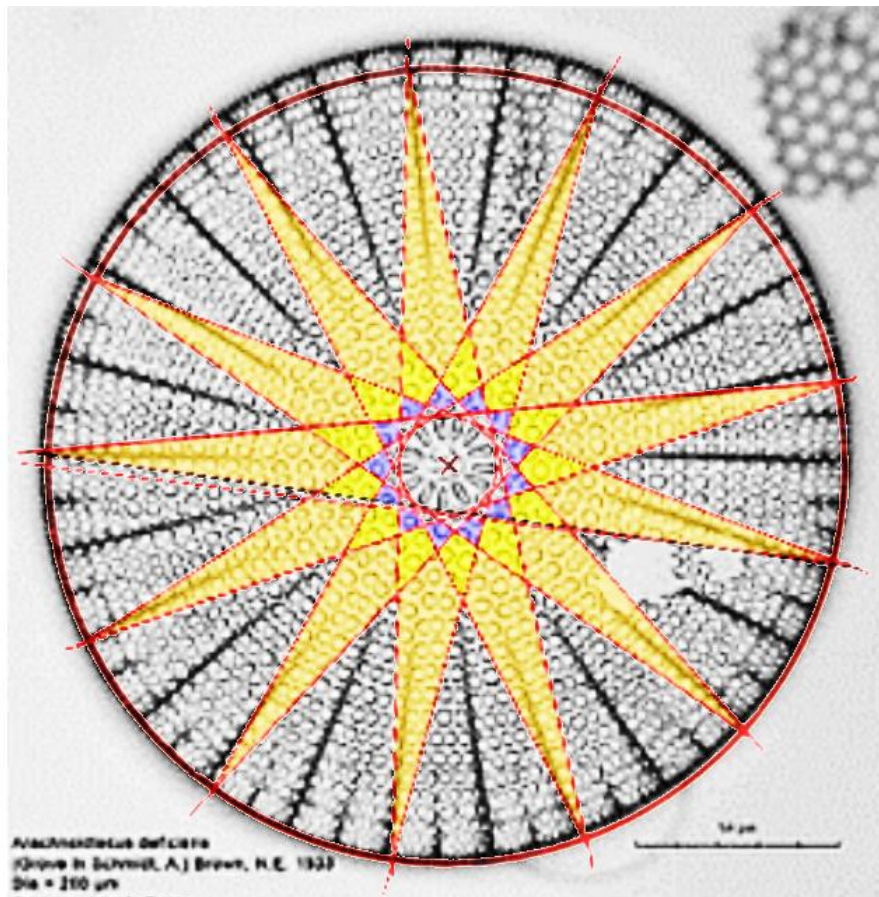
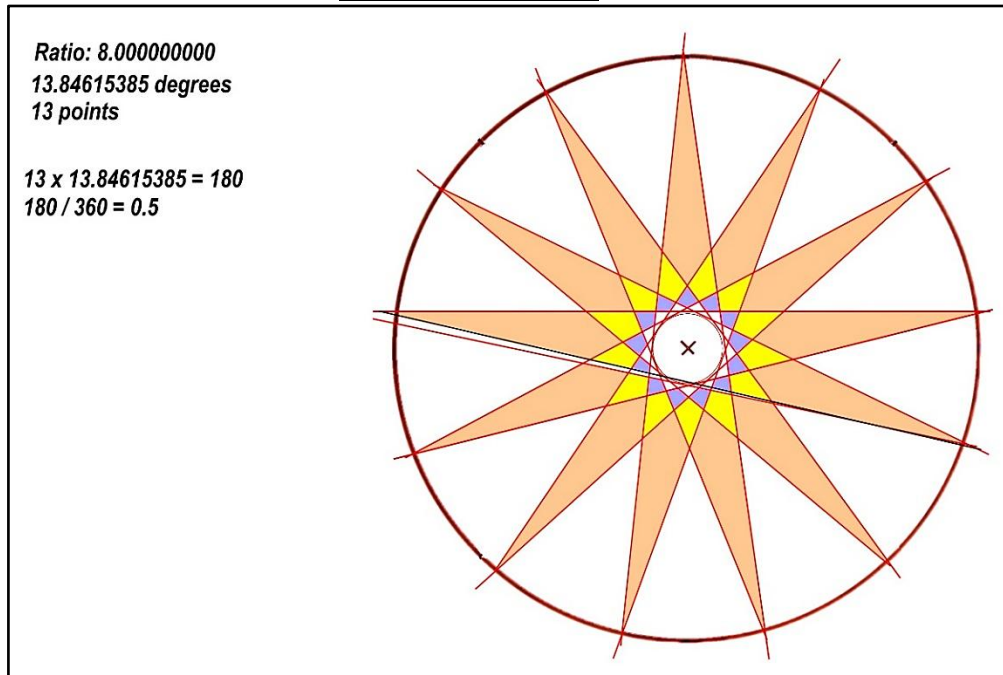

THE 'INNER ROLLER BEARINGS' INDICATE **13 POINTS** OR RADIALS.
A GOOD CANDIDATE FOR A PRIME SHAPE IN NATURE.

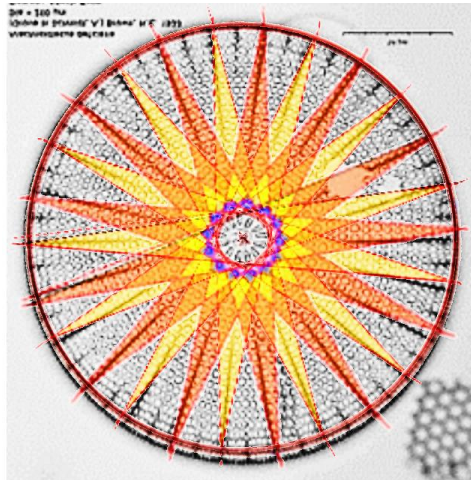

A GOOD CANDIDATE FOR A PRIME SHAPE IN NATURE IN PHASE WITH ITSELF (TWICE).

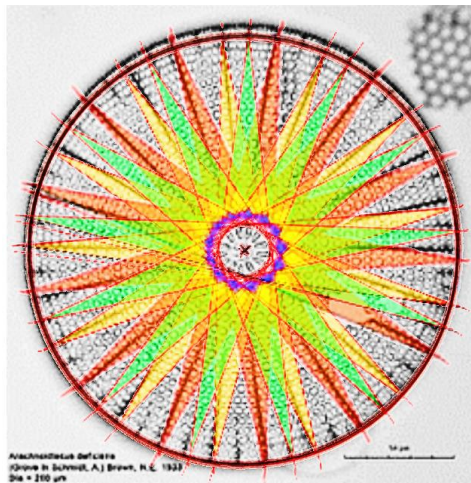

A BETTER CANDIDATE FOR A PRIME SHAPE IN NATURE IN PHASE WITH ITSELF (THREE TIMES).

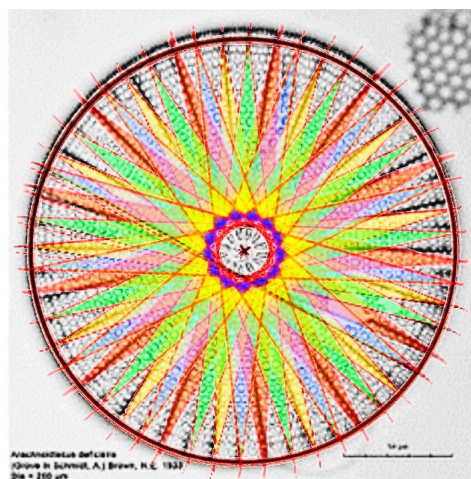

A BETTER CANDIDATE FOR A PRIME SHAPE IN NATURE IN PHASE WITH ITSELF (FOUR TIMES).
 OVERALL IT GIVES THE APPEARANCE OF BEING A 52 POINT POLYGRAM BUT IN REALITY IT IS **4 X 13**
 POINT SEPARATE POLYGRAMS IN PHASE AND NOT A SINGLE 52 POINT POLYGRAM BY ITSELF.
 THE RATIO OF OUTER TO INNER CIRCLES INDICATES THE APPLICABLE SHAPE.

GROWING A SHAPE
 (LIKE GROWING A CRYSTAL IN CHEMISTRY)

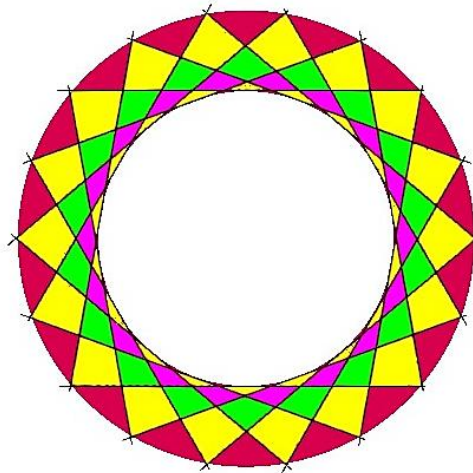

AN EIGHTEEN POINT POLYGRAM

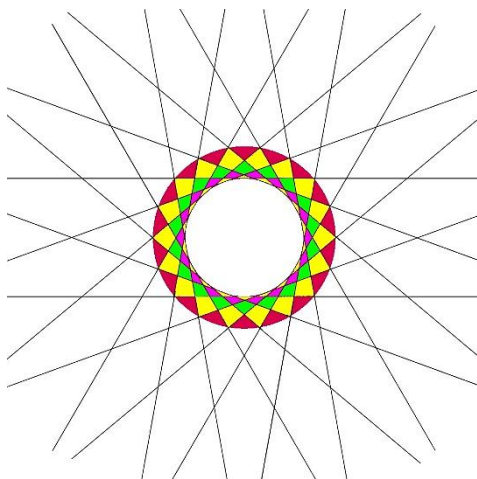

SIDES EXPAND

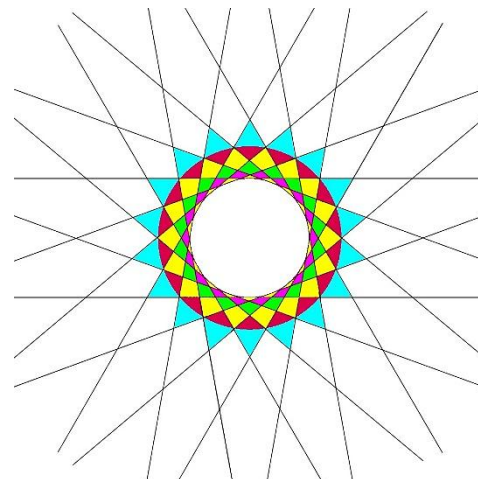

TO REVEAL 6 X 3 SIDES (EQUILATERAL TRIANGLES) IN PHASE.

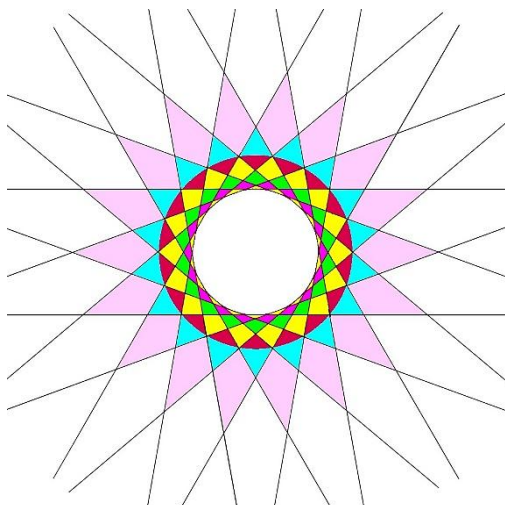

THEN AN EIGHTEEN POINT POLYGRAM

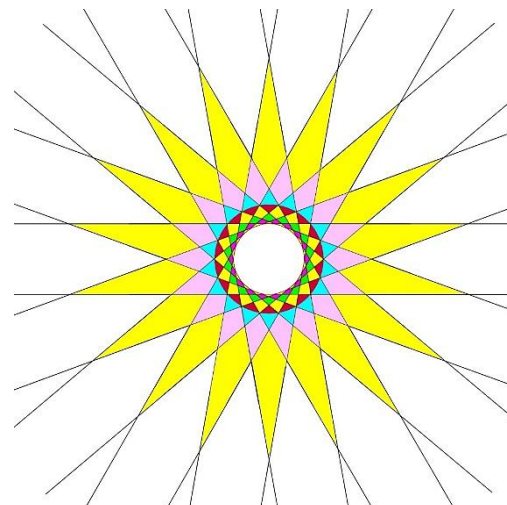

THEN 2 X NONOGRAMS IN PHASE.

TWO NONOGRAMS IN PHASE

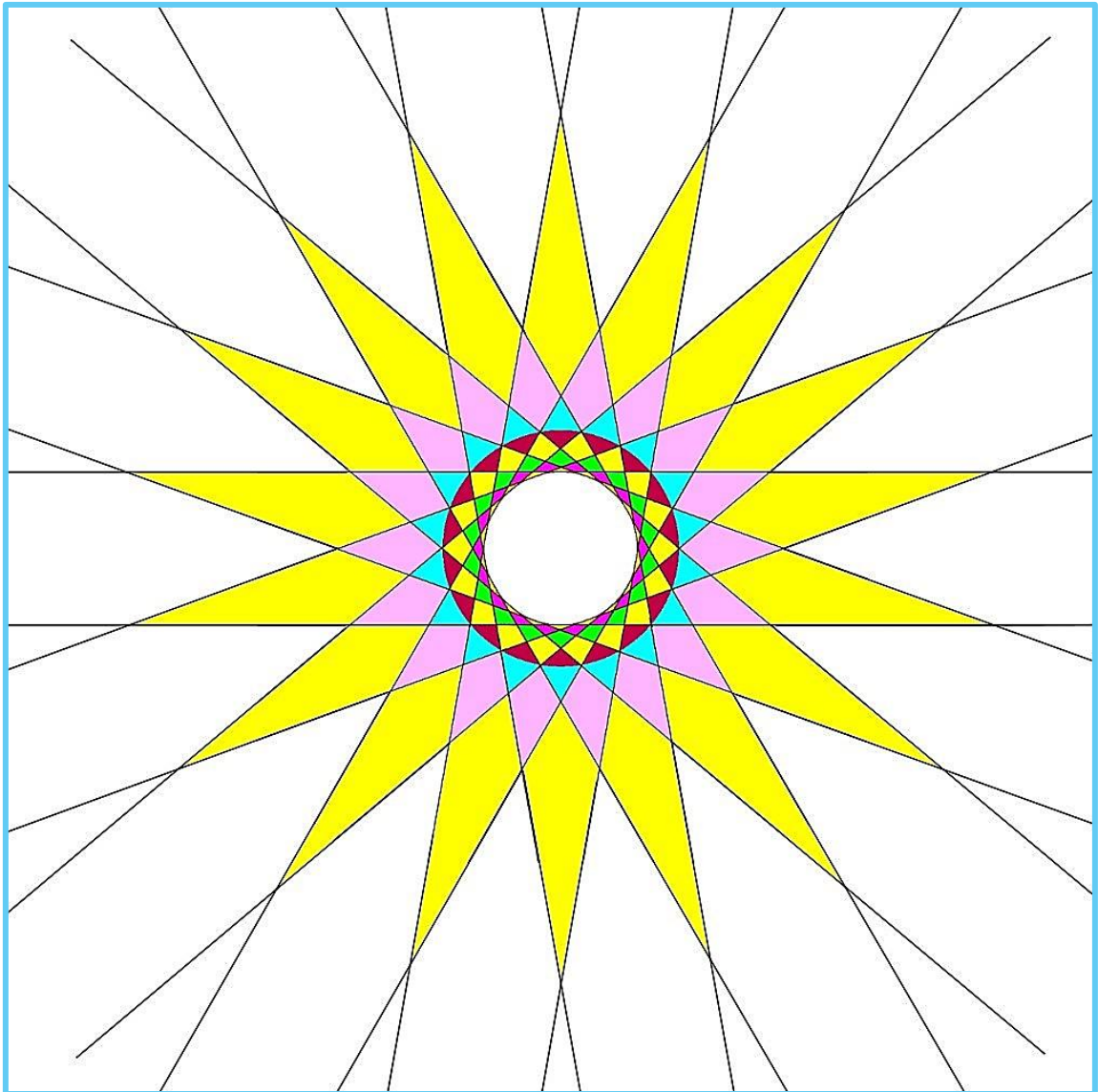

TWO YELLOW 9 POINT POLYGRAMS IN PHASE.
THESE SIDES OF THE 18 POINTS BECOME PARALLEL AND EXTEND TO INFINITY WITHOUT CROSSING AGAIN.

BUT THE PURPLE INNER SHAPE IS AN 18 POINT POLYGRAM. IN THIS INSTANCE THE PAIR OF 9 POINTED OUTER POLYGRAMS IN PHASE HAVE PRODUCED A COMBINED 18 POINT INNER POLYGRAM.

THE BLUE POLYGRAM INSIDE AGAIN IS MADE UP OF 6 EQUILATERAL TRIANGLES IN PHASE.

THE YELLOW POLYGRAM INSIDE OF THAT IS AN 18 POINT POLYGRAM.

MORPHOGENESIS

QUESTION:

*IS THIS AN IMAGE OF AN 18 POINT POLYGRAM OR OF TWO 9 POINT ONES IN PHASE?
AN ALEXANDER LAUTERWASSER IMAGE WITH MY SHAPE DRAWN UPON IT:*

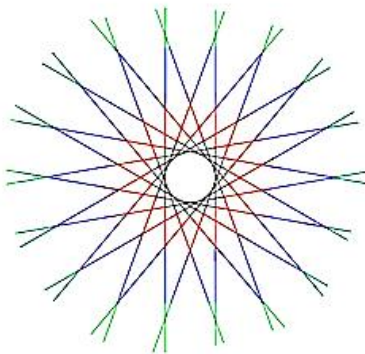
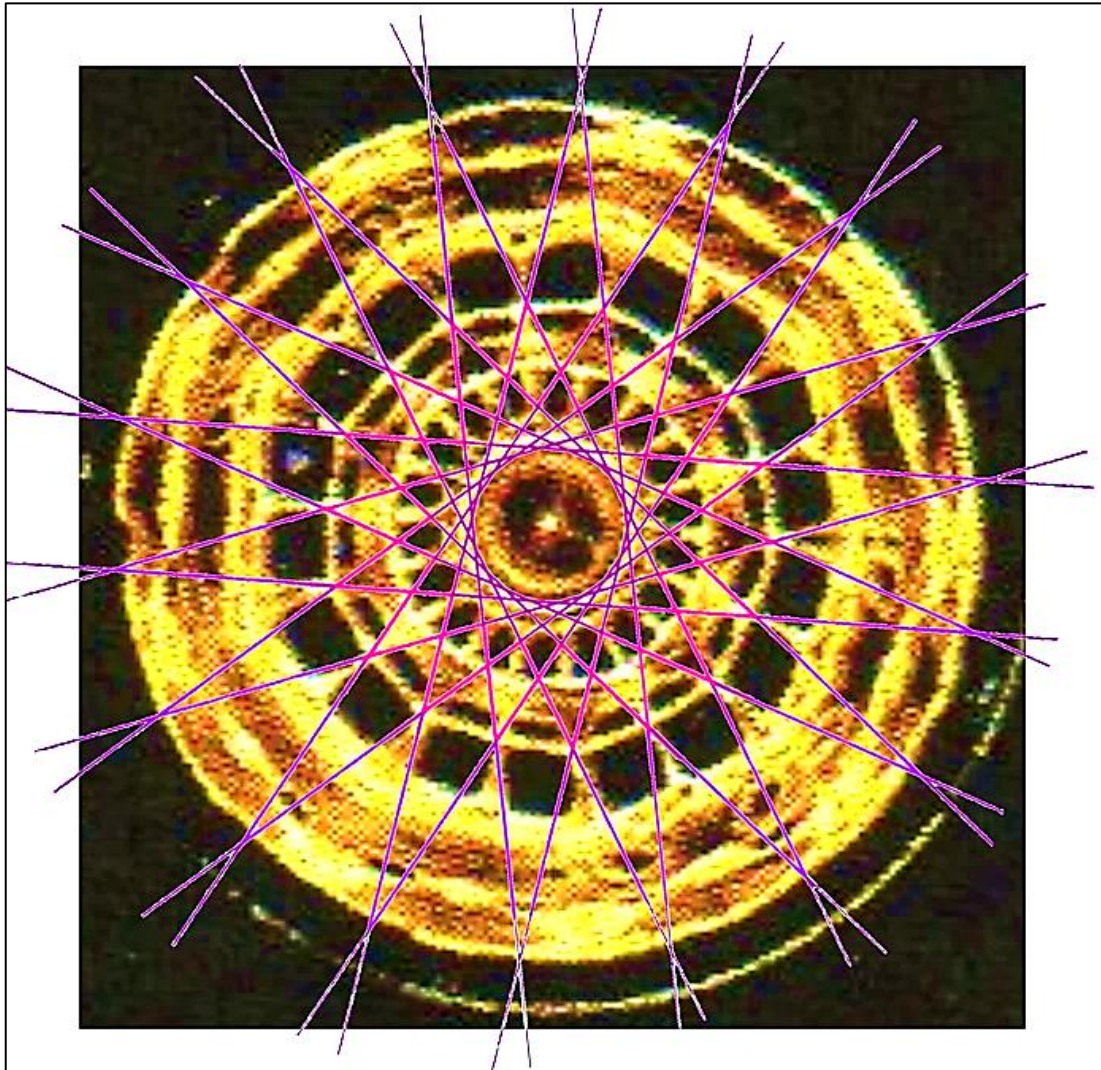

When this 18 point polygram is laid over the image the points where each line intersects another falls upon a circle created by the water sound image.

This is the clue to unravelling the secrets of the mathematics that lay hidden within the shapes. This indicates that although the image and overlay are for one 18 point polygram it is made up of other inner or 'harmonic' polygrams which align with the circles.

LOOK AT THE CIRCLES!

THE APEXES OF INTERMEDIATE SHAPES ALIGN WITH THE IMAGE'S CIRCLES.
SO, THE CIRCLES EXIST IN A SPECIFIC RATIO TO EACH OTHER.
EACH AND EVERY FEATURE IN THIS IMAGE IS RELEVANT TO ITS OVERALL OUTER SHAPE.

Information in the Holographic Universe by Jacob D. Bekenstein [July 14,2003]

"Excerpt: Theoretical results about black holes suggest that the universe could be like a gigantic hologram

Ask anybody what the physical world is made of, and you are likely to be told "matter and energy."

Yet if we have learned anything from engineering, biology and physics, information is just as crucial an ingredient. The robot at the automobile factory is supplied with metal and plastic but can make nothing useful without copious instructions telling it which part to weld to what and so on. A ribosome in a cell in your body is supplied with amino acid building blocks and is powered by energy released by the conversion of ATP to ADP, but it can synthesize no proteins without the information brought to it from the DNA in the cell's nucleus. Likewise, a century of developments in physics has taught us that information is a crucial player in physical systems and processes. Indeed, a current trend, initiated by John A. Wheeler of Princeton University, is to regard the physical world as made of information, with energy and matter as incidentals.

This viewpoint invites a new look at venerable questions. The information storage capacity of devices such as hard disk drives has been increasing by leaps and bounds. When will such progress halt? What is the ultimate information capacity of a device that weighs, say, less than a gram and can fit inside a cubic centimeter (roughly the size of a computer chip)? How much information does it take to describe a whole universe? Could that description fit in a computer's memory? Could we, as William Blake memorably penned, "see the world in a grain of sand," or is that idea no more than poetic license?

Remarkably, recent developments in theoretical physics answer some of these questions, and the answers might be important clues to the ultimate theory of reality. By studying the mysterious properties of black holes, physicists have deduced absolute limits on how much information a region of space or a quantity of matter and energy can hold. Related results suggest that our universe, which we perceive to have three spatial dimensions, might instead be "written" on a two-dimensional surface, like a hologram. Our everyday perceptions of the world as three-dimensional would then be either a profound illusion or merely one of two alternative ways of viewing reality. A grain of sand may not encompass our world, but a flat screen might.

A Tale of Two Entropies: Formal information theory originated in seminal 1948 papers by American applied mathematician Claude E. Shannon, who introduced today's most widely used measure of information content: entropy. Entropy had long been a central concept of thermodynamics, the branch of physics dealing with heat. Thermodynamic entropy is popularly described as the disorder in a physical system. In 1877 Austrian physicist Ludwig Boltzmann characterized it more precisely in terms of the number of distinct microscopic states that the particles composing a chunk of matter could be in while still looking like the same macroscopic chunk of matter. For example, for the air in the room around you, one would count all the ways that the individual gas molecules could be distributed in the room and all the ways they could be moving."

"When Shannon cast about for a way to quantify the information contained in, say, a message, he was led by logic to a formula with the same form as Boltzmann's. The Shannon entropy of a message is the number of binary digits, or bits, needed to encode it. Shannon's entropy does not enlighten us about the value of information, which is highly dependent on context. Yet as an objective measure of quantity of information, it has been enormously useful in science and technology. For instance, the design of every modern communications device--from cellular phones to modems to compact-disc players--relies on Shannon entropy.

Thermodynamic entropy and Shannon entropy are conceptually equivalent: the number of arrangements that are counted by Boltzmann entropy reflects the amount of Shannon information one would need to implement any particular arrangement. The two entropies have two salient differences, though. First, the thermodynamic entropy used by a chemist or a refrigeration engineer is expressed in units of energy divided by temperature, whereas the Shannon entropy used by a communications engineer is in bits, essentially dimensionless. That difference is merely a matter of convention.

Even when reduced to common units, however, typical values of the two entropies differ vastly in magnitude. A silicon microchip carrying a gigabyte of data, for instance, has a Shannon entropy of about 10^{10} bits (one byte is eight bits), tremendously smaller than the chip's thermodynamic entropy, which is about 10^{23} bits at room temperature. This discrepancy occurs because the entropies are computed for different degrees of freedom. A degree of freedom is any quantity that can vary, such as a coordinate specifying a particle's location or one component of its velocity. The Shannon entropy of the chip cares only about the overall state of each tiny transistor etched in the silicon crystal--the transistor is on or off; it is a 0 or a 1--a single binary degree of freedom. Thermodynamic entropy, in contrast, depends on the states of all the billions of atoms (and their roaming electrons) that make up each transistor. As miniaturization brings closer the day when each atom will store one bit of information for us, the useful Shannon entropy of the state-of-the-art microchip will edge closer in magnitude to its material's thermodynamic entropy. When the two entropies are calculated for the same degrees of freedom, they are equal.

What are the ultimate degrees of freedom? Atoms, after all, are made of electrons and nuclei, nuclei are agglomerations of protons and neutrons, and those in turn are composed of quarks. Many physicists today consider electrons and quarks to be excitations of superstrings, which they hypothesize to be the most fundamental entities. But the vicissitudes of a century of revelations in physics warn us not to be dogmatic. There could be more levels of structure in our universe than are dreamt of in today's physics.

One cannot calculate the ultimate information capacity of a chunk of matter or, equivalently, its true thermodynamic entropy, without knowing the nature of the ultimate constituents of matter or of the deepest level of structure, which I shall refer to as level X. (This ambiguity causes no problems in analyzing practical thermodynamics, such as that of car engines, for example, because the quarks within the atoms can be ignored--they do not change their states under the relatively benign conditions in the engine.) Given the dizzying progress in miniaturization, one can playfully contemplate a day when quarks will serve to store information, one bit apiece perhaps. How much information would then fit into our one-centimeter cube? And how much if we harness superstrings or even deeper, yet undreamt of levels? Surprisingly, developments in gravitation physics in the past three decades have supplied some clear answers to what seem to be elusive questions."

BLACK HOLE THERMODYNAMICS

"A central player in these developments is the black hole. **Black holes are a consequence of general relativity**, Albert Einstein's 1915 **geometric** theory of gravitation. In this theory, **gravitation arises from the curvature of spacetime**, which makes objects move as if they were pulled by a force. ***Conversely, the curvature is caused by the presence of matter and energy.***

According to Einstein's equations, ***a sufficiently dense concentration of matter or energy*** will curve spacetime so extremely that **it rends, forming a black hole.**

The laws of relativity forbid anything that went into a black hole from coming out again, at least within the classical (**nonquantum**) description of the physics.

The point of no return, called the **event horizon** of the black hole, is of crucial importance. In the simplest case, the horizon is a sphere, whose surface area is larger for more massive black holes.

It is impossible to determine what is inside a black hole. No detailed information can emerge across the horizon and escape into the outside world.

In disappearing forever into a black hole, however, a piece of matter does leave some traces. Its energy (we count any mass as energy in accordance with Einstein's $E = mc^2$) is permanently reflected in an increment in the black hole's mass.

If the matter is captured while circling the hole, its associated angular momentum is added to the black hole's angular momentum.

Both the mass and angular momentum of a black hole are measurable from their effects on spacetime around the hole.

In this way, the laws of conservation of energy and angular momentum are upheld by black holes.

Another fundamental law, **the second law of thermodynamics**, appears to be violated. The second law of thermodynamics summarizes the familiar observation that ***most processes in nature are irreversible***: a teacup falls from the table and shatters, but no one has ever seen shards jump up of their own accord and assemble into a teacup. The second law of thermodynamics forbids such inverse processes.

It states that the entropy of an isolated physical system can never decrease; at best, entropy remains constant, and usually it increases. This law is central to physical chemistry and engineering; it is arguably the physical law with the greatest impact outside physics."

A PREVIOUS BOOK BY THIS AUTHOR

CIRCLE OF INNER HARMONY

LINKING PLANE REGULAR SHAPES
AND
NUCLEAR PHYSICS

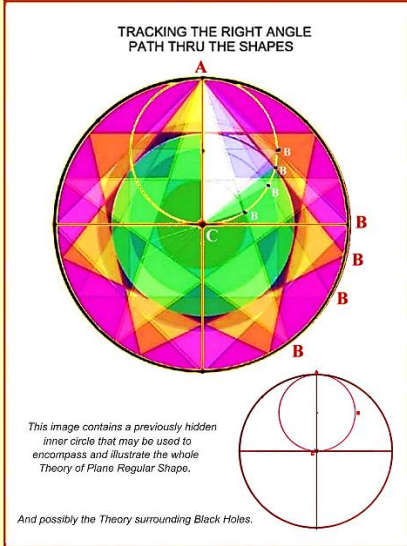

John Marcus Crombie

A PREVIOUS BOOK BY THIS AUTHOR

THE CRADLE OF GEOMETRY

THE ATEN & ITS RAYS
A SHAPE THEORY

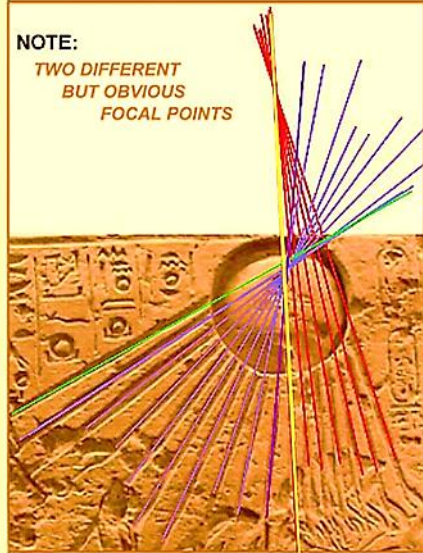

John Marcus Crombie

A PREVIOUS BOOK BY THIS AUTHOR

STONEHENGE

DESIGNED AND BASED ON
**THE GRAPHICS & MATHEMATICS
OF PLANE REGULAR SHAPE**

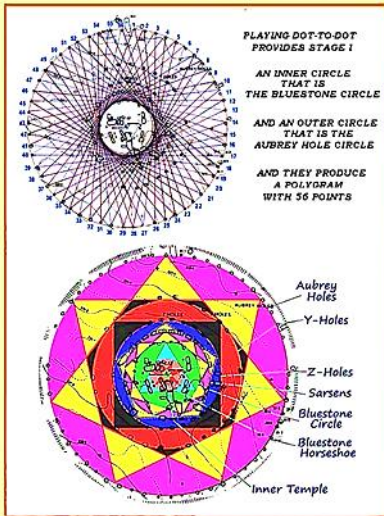

John Marcus Crombie

THIS BOOK BY THIS AUTHOR

**MODERN NUCLEAR THEORY
&
PLANE REGULAR SHAPE**

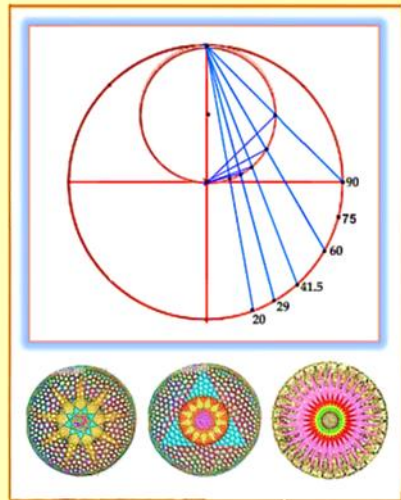

John Marcus Crombie